

## Fitting the appliance into framing

1. Fold out four mounting tabs and install the appliance in the framing as shown.
2. Fasten the unit to framing using 4 screws or nails at the mounting tabs.

**Note:** The **sheet metal strip** at the bottom of the appliance **must be flush with the framing studs**.

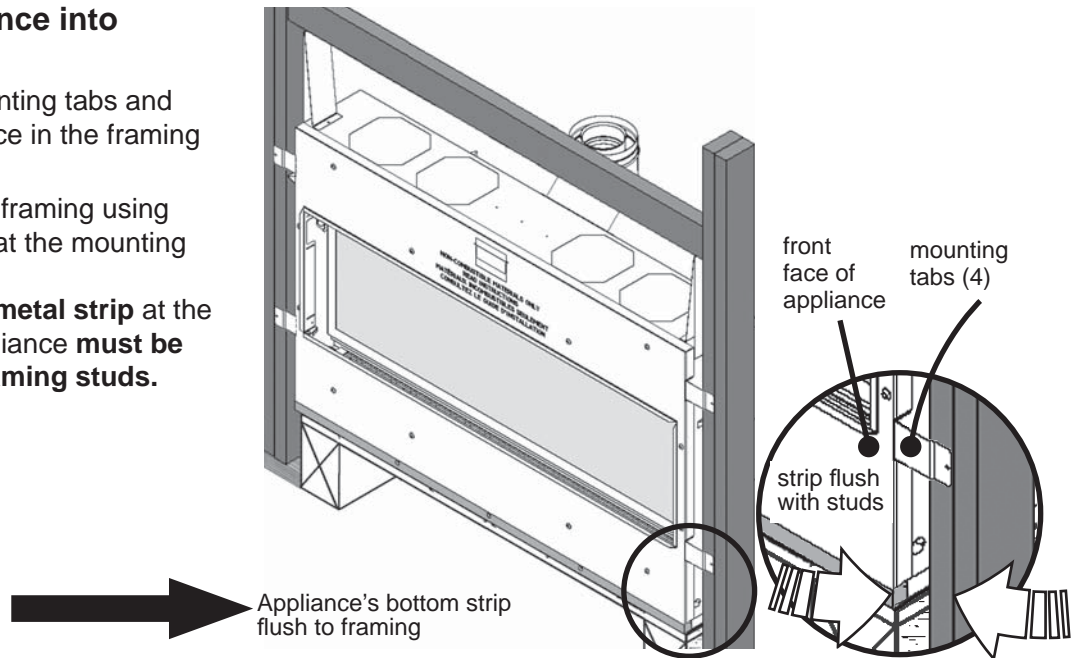

## Minimum Cement Board Dimensions

Minimum coverage area of non-combustible cement board.  
Any **wall** finish applied to shaded area must be non-combustible.

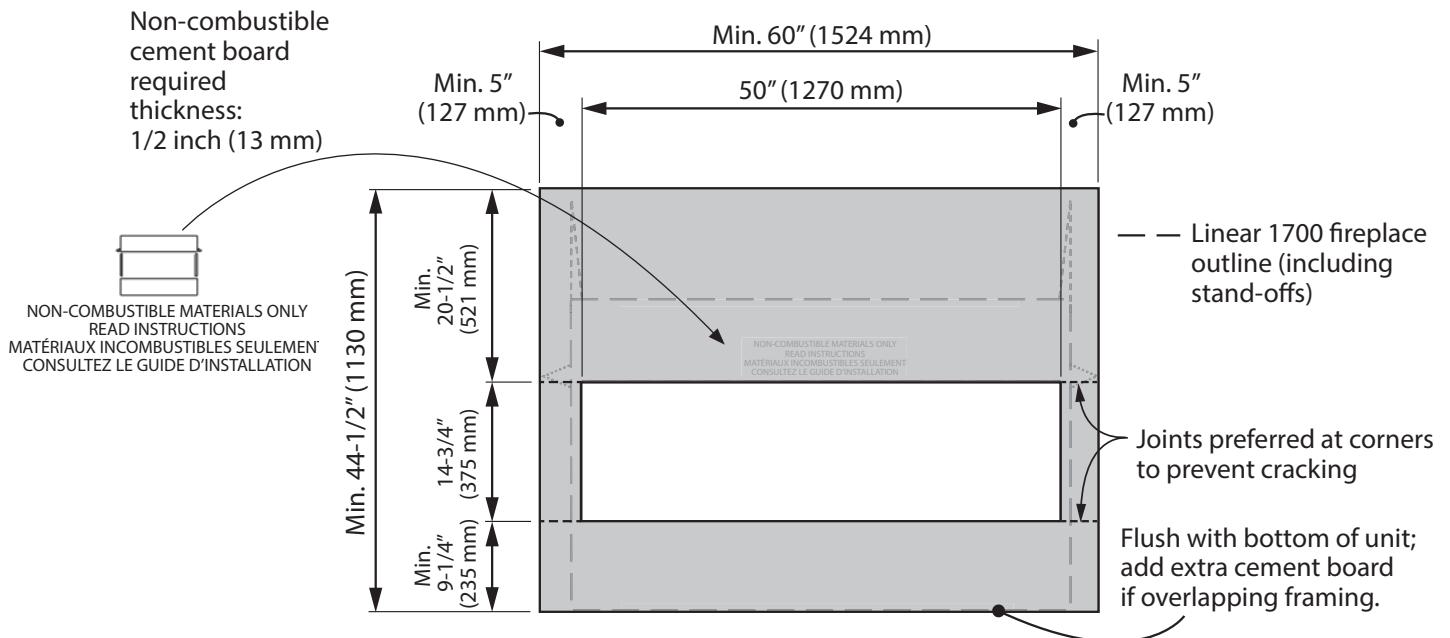

## Wall Finishing

### Non-combustible cement board

The L2 Linear fireplace requires a 1/2" (13 mm) thick non-combustible cement board to be used as a wall surface immediately surrounding the unit on each side—see diagram below for minimum coverage.

Extending the cement board well beyond the minimum shown will help avoid cracking due to differential expansion of materials.

Pre-drill cement board with oversized holes and do not over-tighten screws to avoid cracking due to heat expansion.

Standard gypsum wall board may be used beyond the perimeter of the cement board.

### Non-combustible finishing over cement board

Additional non-combustible material such as tile, etc., may be applied over top of the cement board or you may choose to leave it finished clean with no tile—see page 38. Be aware that a trim is always required and that only the 1755 and 1750 style trims will accept tile, etc. tucked behind them (up to 5/8" thick for the 1755 and up to 1 inch thick for the 1750). Finish **should not cover** the trims.

### Cracking wall finishes

**We recommend installing the optional LDK Duct Kit to reduce the wall temperatures and minimize the possibility of cracking wall finishes.**

If a clean finish with no tile, etc. is desired, joints in the cement board and the transition to gypsum board will require special attention if future cracking is to be controlled. Be aware that temperatures on the non-combustible wall surface above the appliance can exceed 250°F.

Below are some tips on how to best avoid any cracking:

- Allow materials to dry thoroughly before finishing the wall. Cement board has the ability to absorb up to 30 percent of its weight in water and may shrink as much as 1/8" over a 48" length when drying from a saturated condition. Running the fireplace before final finishing will help drive out moisture.

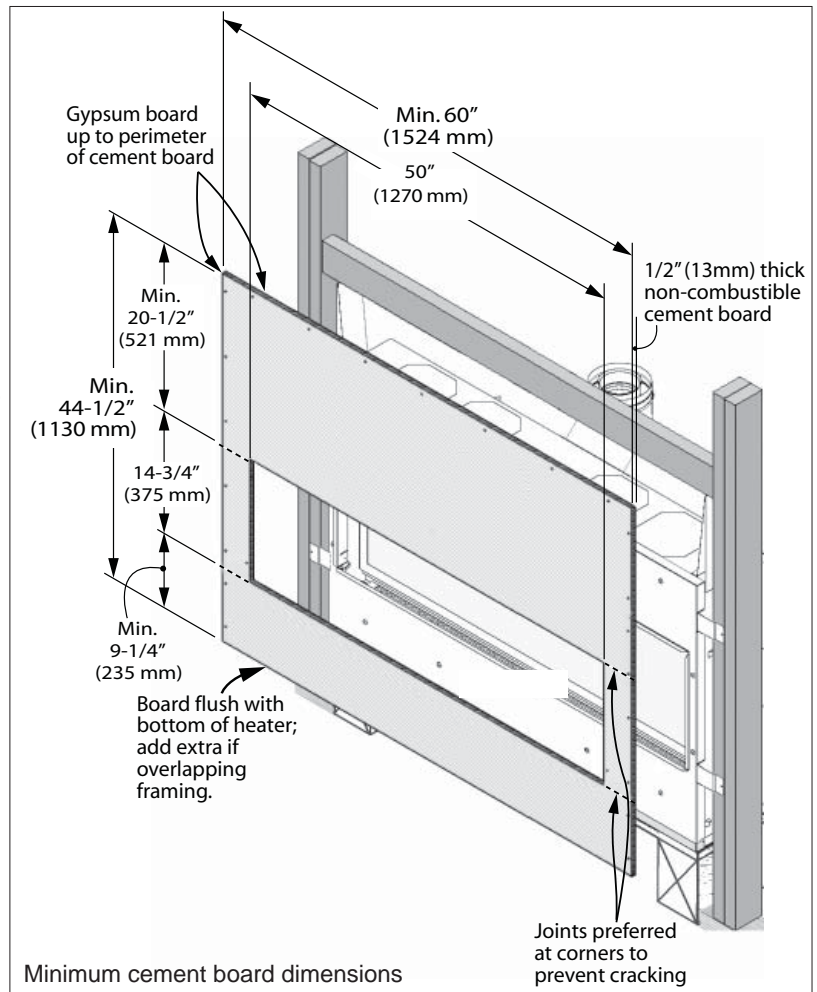

- Always pre-drill screw holes through cement board and use screws with self-milling head.
- Always use tape over joints.
- Behind joints, double up studs or use studs "on the flat" to add extra support to the joint. Adhesive on the backside of wall board behind any joints can help control differential movement.
- Use multiple, thinner coats of joint compound and allow to dry thoroughly between coats.
- Ensure framing materials are dry.
- After finishing the wall, introduce heat gradually to slowly dry any excess moisture rather than drying too fast.
- Avoid notching cement board or tiles around corners of window opening and instead provide a joint that intersects the corner. Avoid notching cement board or tiles around corners of window opening and instead provide a joint that intersects the corner.

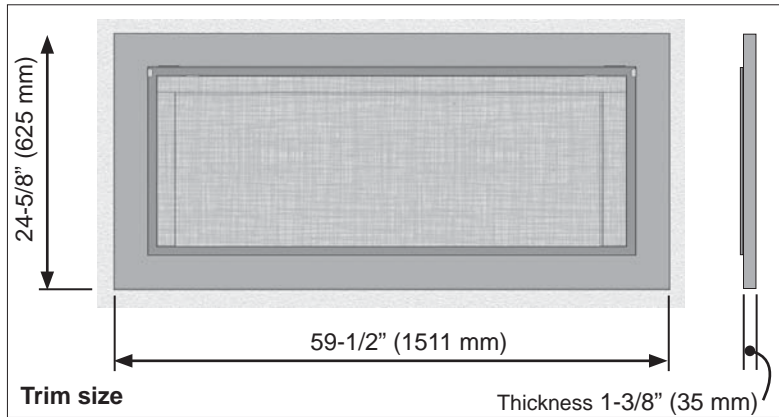

**1750 5-1/4" Steel Trim**

Wider trim, can adjust up to 1" forward of surface of cement board

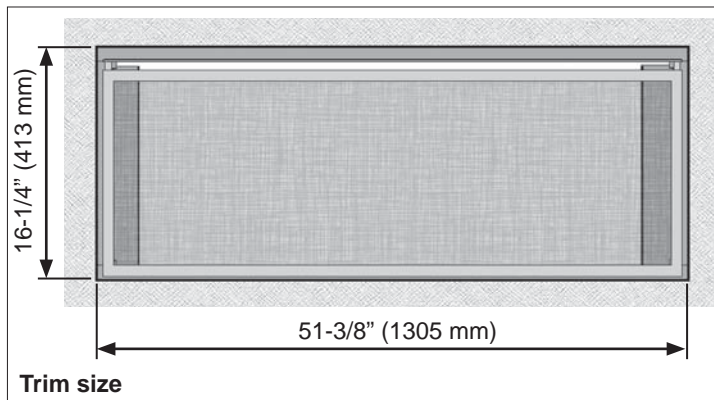

**1755 1" Steel Trim**

Narrow trim, can adjust up to 5/8" forward of surface of cement board