

# # 3336 Closure Plate for 530/922 Model Heaters

## INSTALLATION INSTRUCTIONS

Nov 2003

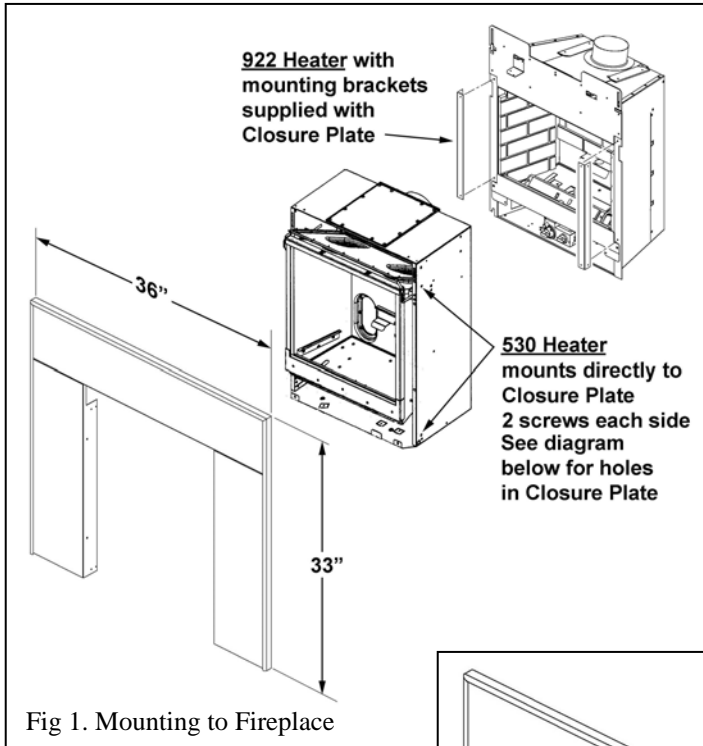

Fig 1. Mounting to Fireplace

### General

The 3336 Closure Plate is a 33" high x 36" wide black powder coated sheet metal plate trimmed with black extruded aluminum which can be used with either the 530 or 922 model Fireplaces to cover larger openings on insert applications. The Closure Plate mounts directly to the 530 fireplace while the 922 fireplace requires adapter brackets which are shipped with the closure plate.

### Installation

- Lay the panels out face down on the floor and assemble using the bolts supplied ( see fig 3 )
- Assemble the aluminum extrusion using the corner brackets supplied and slide over the outer perimeter of the closure plate.
- Insert the long tapping screw through the hole at the bottom of the right and left extrusion pieces and tighten until extrusion is snug to the closure plate ( screw tension should not show from the front as it

will strike the back of the plate hidden by the extrusion)

- Mount the closure plate to the fireplace ( 530 fireplace only) using 2 screws per side through the appropriate hole in the closure plate for the front trim used ( see figs 1 & 2). The 922 fireplace will first require the adapter brackets to be mounted to the closure plate then the closure plate mounted to the fireplace ( mounting brackets are completely symmetrical and can therefore mount to either side, (see figs 1 & 2)

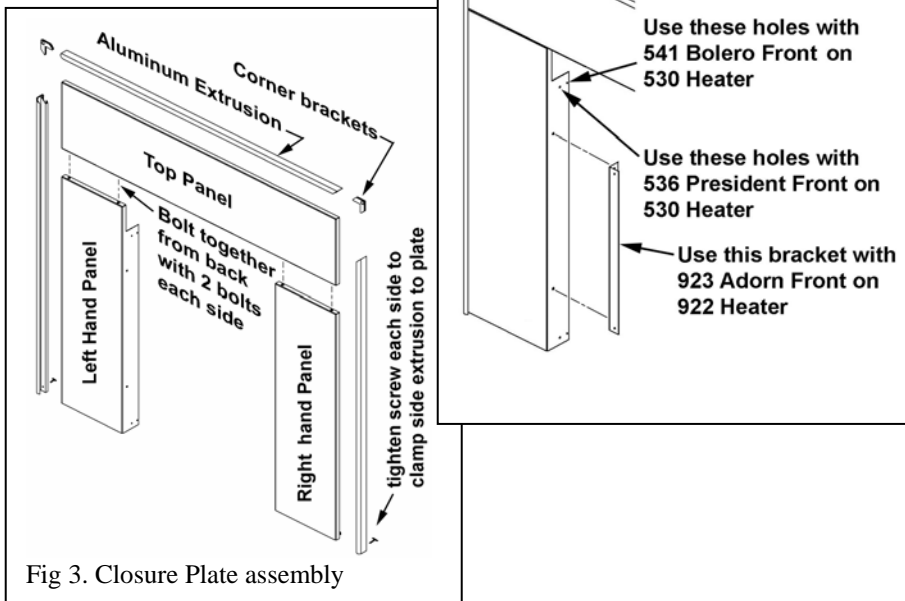

Fig 3. Closure Plate assembly

Manufactured and distributed in Canada and USA by

Miles Industries Ltd.

829 West Third Street, North Vancouver B.C, CANADA, V7P 3K7

Ph. (604) 984-3496 Fax (604) 984-0246