



#975 ZERO CLEARANCE KIT

Sept 2003

INSTALLATION INSTRUCTIONS

approved for use only with **VALOR MODEL 922 Adorn Fireplace**

1. GENERAL

Model 975ZCK zero clearance kit must be used when installing Fireplace Model 922 into an enclosure constructed of combustible material and connected to an approved venting system. Either the 923 Adorn or the 539/549 Windsor Arch cast fronts may be used with the 922 fireplace installed in the 975 Zero Clearance Kit.

2. FRAMING.

Minimum clearances to combustible materials and framing details are shown in fig.1. Though not mandatory, we recommend that a hard surfaced hearth area be maintained in front of the fireplace for both aesthetic and maintenance purposes. This may be finished in brick, ceramic tile, marble, etc. Raising the hearth slightly will help to minimize dust and lint accumulation under the unit. Refer to the 922 installation manual for mantle clearances as they vary with the different from trims.

To enable the heater to be installed correctly the height of the finished hearth must be known before installing this kit, please note the bottom of the kit must be installed at the planned finished hearth height (including tile etc.).

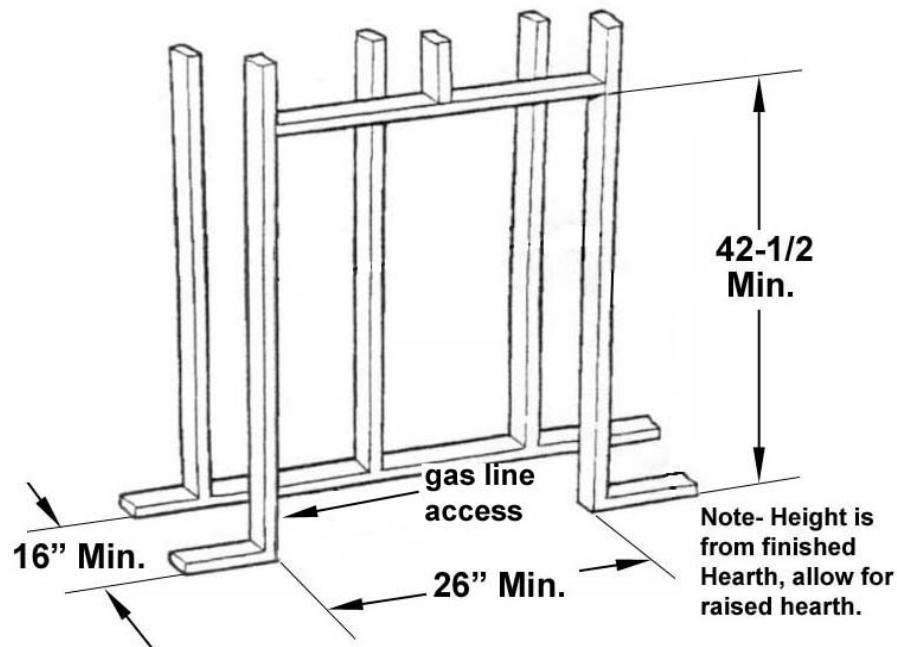

Fig. 1 framing dimensions

4000 483

3. ZERO CLEARANCE KIT COMPONENTS

The complete #975ZCK contains the following:

- Double wall Z.C box
- Top shield
- Sheet metal cement board support
- 4-top stand-offs
- 4" dia. vent connector
- 4" dia. x 14" long Alu flex liner.
- 2 - 4" dia. S.S gear clamps
- Bag of screws

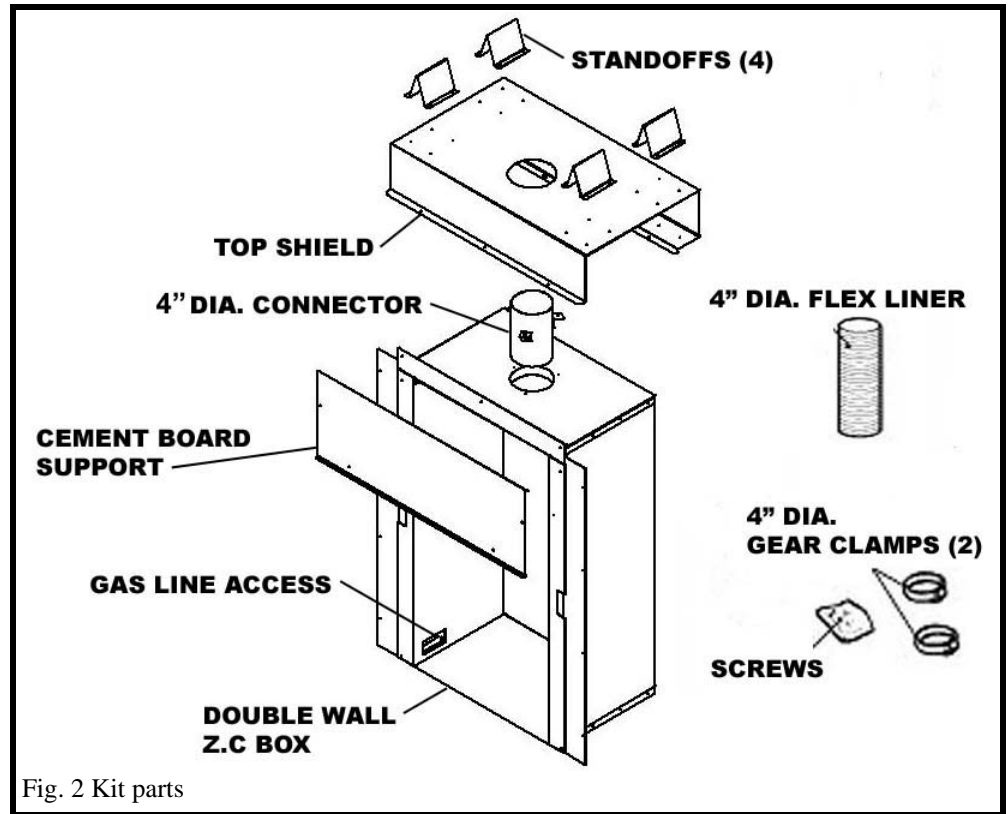

4. ASSEMBLE THE ZERO CLEARANCE KIT

- Push the vent connector through the top of the zero clearance box, long side down, and secure using three screws.
- Secure the top shield to the zero clearance box using six sheet metal screws (see fig 2)
- Secure the standoffs to the top spacer using 16 screws (fig 2).

• 5. SECURE THE ZERO CLEARANCE KIT TO THE FRAMING

- Place the kit in the framing. Note – bottom of the zero clearance kit should be installed flush with the top of finished hearth. Allow for raised hearth.
- Hook the sheet metal cement board support over the top flange and secure through two holes. (see fig 3)
- Secure the front flange of the zero clearance kit to the framing.(see fig 3)
- Connect 4” dia “B” type vent to the vent connector on top of the zero clearance box.
- Attach the 4” dia flex liner to the vent connector, located on the underside of the top panel, using one of the gear clamps provided.
- **Non-combustible material (i.e. wonder board, cement board, etc.) must be attached to the framing and the front flanges of the zero clearance box as shown in fig. 4.**
- All wall and hearth finishes may now be applied.

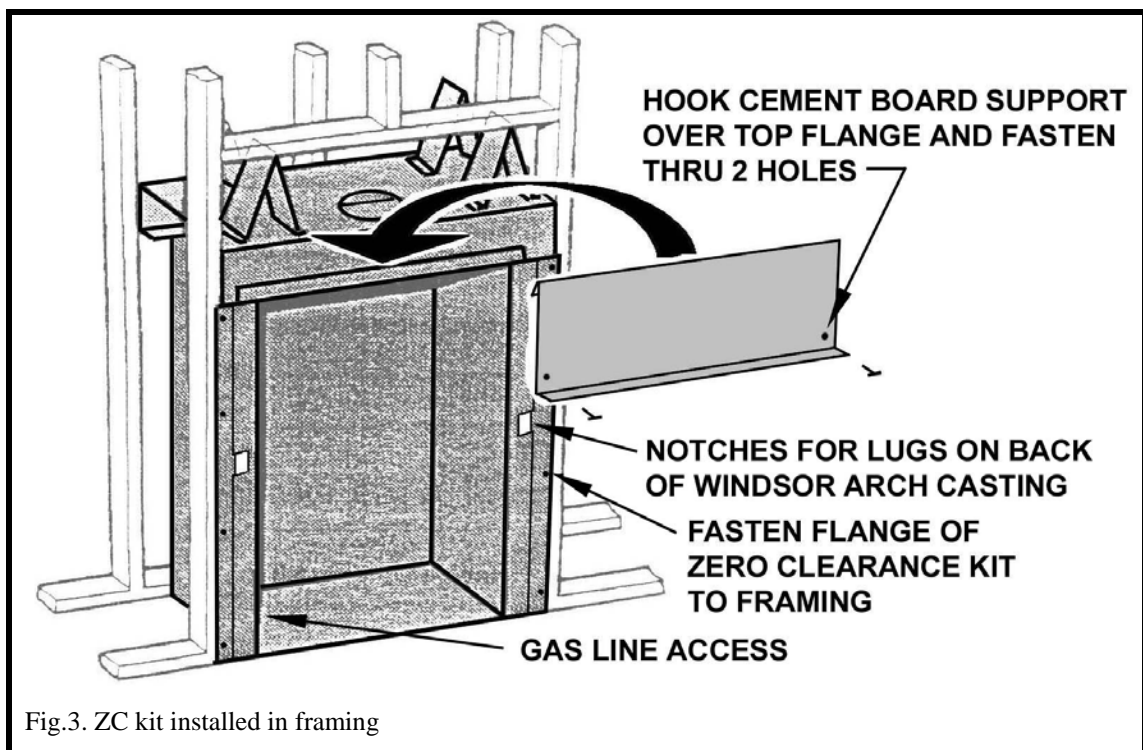
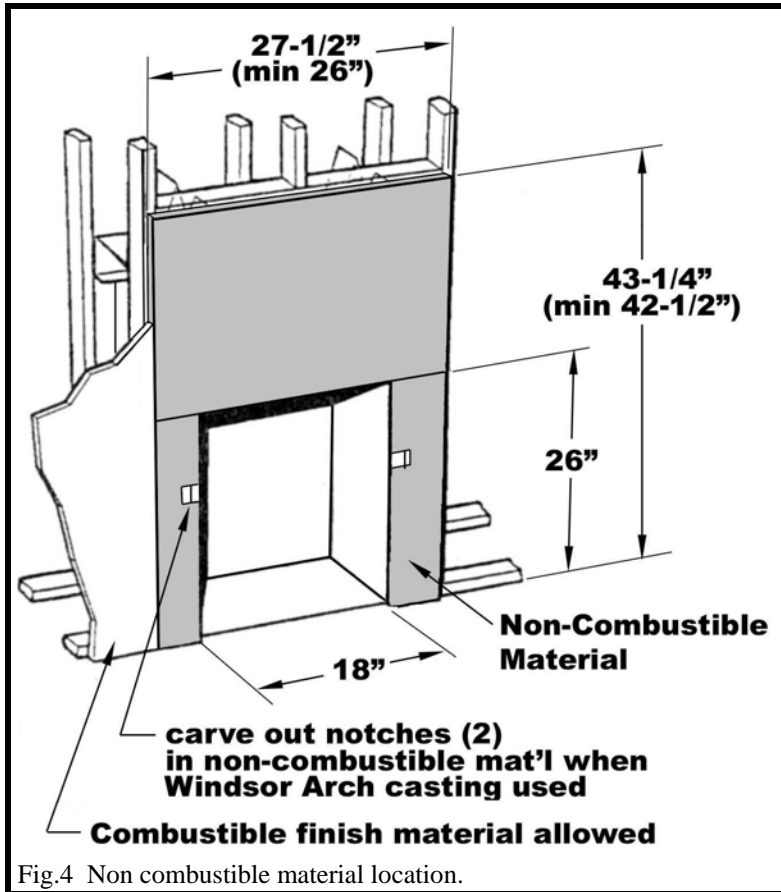

Fig.3. ZC kit installed in framing

6. Finishing the Wall

Non-Combustible material such as Wonderboard must be used around the perimeter of the Z.C Kit to the extents shown in fig 4. Combustible mantles (in some cases) may be allowed within the perimeter of the Wonderboard – refer to the 922 installation manual for mantle clearances for the various front trims. Drywall/Sheetrock may be used beyond the perimeter of the Wonderboard .



7. INSTALLING THE APPLIANCE

The unit can now be installed exactly as in a masonry fireplace, see 922 installation and owner's manual. Refer to installation manual for mantle clearances as they vary with the different front trims.

Please note that the second gear clamp, supplied with this kit, and is to secure the 4" dia flex. vent to the vent collar on the appliance.

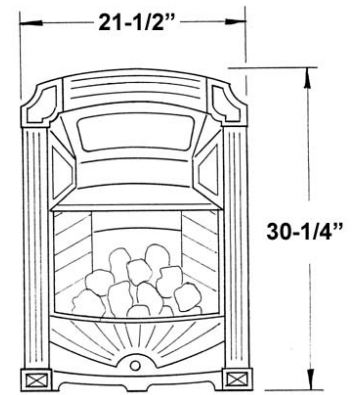

923 Adorn Front

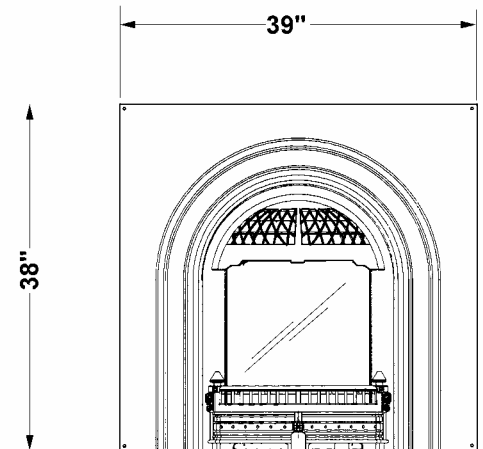

539 Windsor Arch Front with Plate

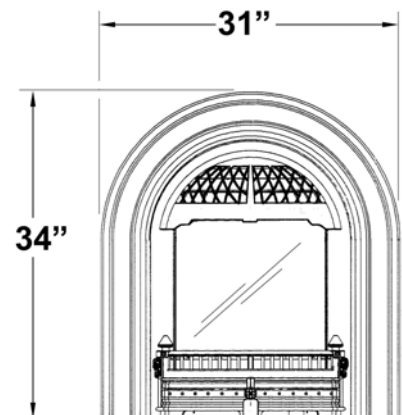

549 Windsor Arch Front w/o Plate

**PLEASE LEAVE INSTALLATION AND OPERATING INSTRUCTIONS WITH THE
HOMEOWNER.**

LIMITED WARRANTY POLICY

Miles Industries Ltd. warrants all components of the model 975 zero clearance kit for a period of two years from the date of purchase against defects in materials or workmanship. This warranty covers only the cost of defective parts and applies only to the original consumer purchaser. The replacement of defective parts by Miles Industries Ltd. will be without charge during the warranty period. This warranty does not extend to (1) components damaged by accident, neglect, misuse, abuse, alteration, and negligence of others, including the installation thereof by unqualified installers' (2) the costs of removal, reinstallation or transportation of defective parts or (3) incidental or consequential damages.

THIS WARRANTY IS EXPRESSLY IN LIEU OF ALL OTHER WARRANTIES, EXPRESSED OR IMPLIED, INCLUDING THE WARRANTY OF MERCHANTABILITY OF FITNESS FOR PURPOSE AND OF ALL OTHER OBLIGATIONS OR LIABILITIES. MILES INDUSTRIES LTD DOES NOT ASSUME, NOR HAS IT AUTHORIZED ANY PERSON INCLUDING ITS SALES REPRESENTATIVES TO ASSUME FOR IT, ANY OTHER OBLIGATION OR LIABILITY IN CONNECTION WITH THE SALE OR USE OF THE MODEL 975 ZERO CLEARANCE KIT.

The model 975 zero clearance kit must be installed by a qualified installer in accordance with the instructions furnished. The defective components should be returned at your expense to the dealer from where the product was purchased or authorized service agent. Any components returned for warranty repair/replacement must be accompanied by the sales invoice evidencing proof of purchase and date of purchase. Miles Industries Ltd. reserves the right to repair and return any defective component.

Manufactured and distributed in Western Canada and USA by

Miles Industries Ltd.

829 West Third Street, North Vancouver B.C, CANADA, V7P 3K7

Ph. (604) 984-3496 Fax (604) 984-0246

Copyright 2003