

Framing

The Vogue fitted with a Four-sided Trim **must be framed to accommodate the trim**. The base of the heater must be **at least 1" (25 mm) above** the finished non-combustible hearth or floor and **at least 2" (51 mm) above** the finished combustible hearth or floor. Moreover, the hearth must have a depth of 9" (229 mm).

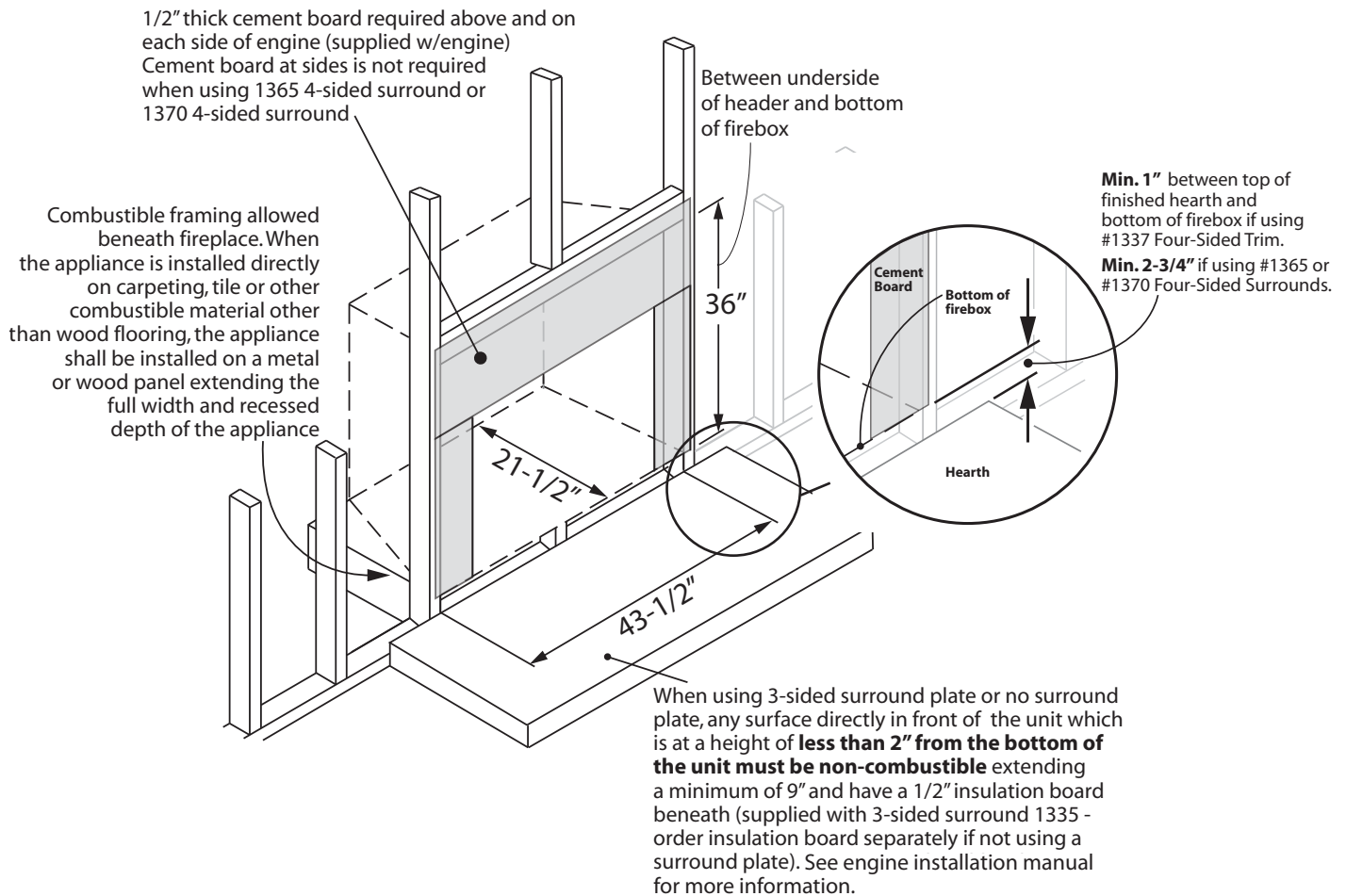

Fitting the appliance into framing

Recess the appliance in the framing in accordance with the surround trim that will be used (if any) and the wall finish details. NOTE: There are three options to consider when positioning the appliance in the framing. Options 1 and 2 are for installations utilizing a surround trim. If you are using a surround trim and you want tile, etc., installed behind, you must use Option 2 when positioning the appliance into the framing.

OPTION 1—with 1335 or 1337 Trims (narrow), Appliance FLUSH to Framing

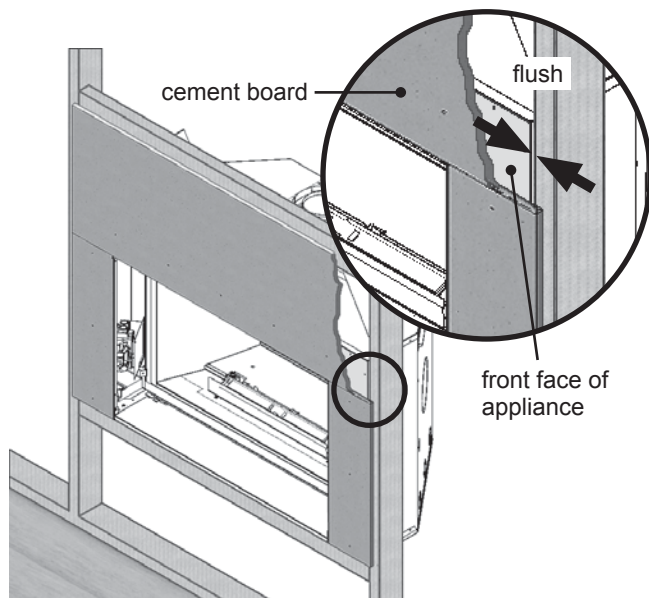

Option 1—with 1335 or 1337, Flush

- Sheet metal front face of the appliance is flush with the framing studs.
- Cement board required on top and on each side of the appliance's opening.
- Additional finishes such as tile, etc., can be butted up to or installed overtop of edge of surround trim. There is no space to install tiles behind the 1335 and 1337 trims.
- Incorporate the hearth insulation board (supplied with the 3-sided surround plate 1335) in the construction of the hearth as required, following the guidelines provided in the *Framing & Hearth Requirements* section of this manual.

OPTION 2—with 1365 or 1370 Trims (wide), Appliance PROTRUDING from Framing

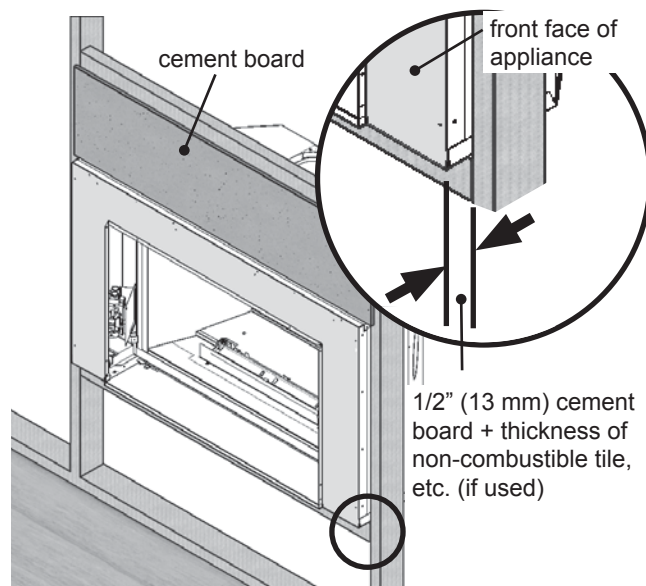

Option 2—with 1365 or 1370, Protruding

- Sheet metal front face of the appliance protrudes in front of the framing studs by 1/2" (13 mm) plus thickness of any non-combustible material over top, such as tiles.
- Cement board side pieces are not required for this option. Top cement board piece may be necessary to span from top surface of appliance to the header above. A steel stud (not supplied) may be added to support the lower edge of the board if necessary.

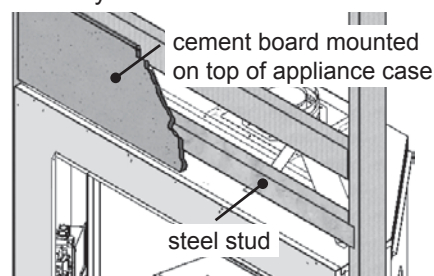

- Drywall install up to sides of appliance.
- Surround can be installed flat against or floating from the finished wall surface.

**OPTION 3—No Trim (1376 Kit), Appliance
RECESSED into Framing**

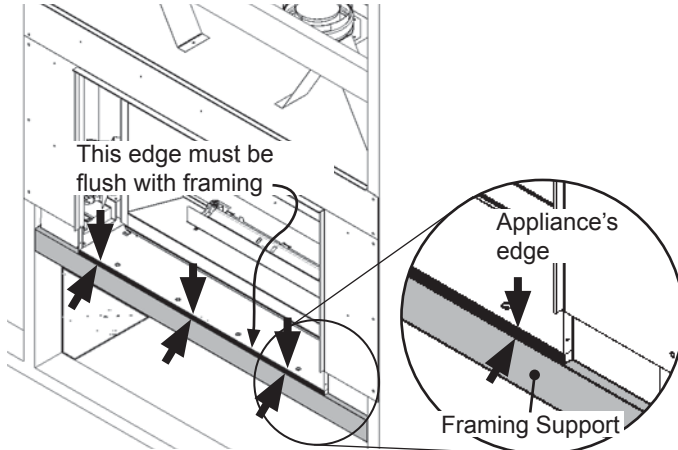

Option 3—with 1376, Recessed

- Follow installation instructions provided with **1376CSK Clean Surround Installation Kit**.
- Appliance recessed 1/2 inch (13 mm) into framing so that its bottom front panel edge is flush with the framing. **Follow installation instructions supplied with 1376CSK Kit.**
- Cement board required on top, on each side, and on the bottom of the appliance's opening for this option. (Bottom piece supplied with 1376CSK Kit).

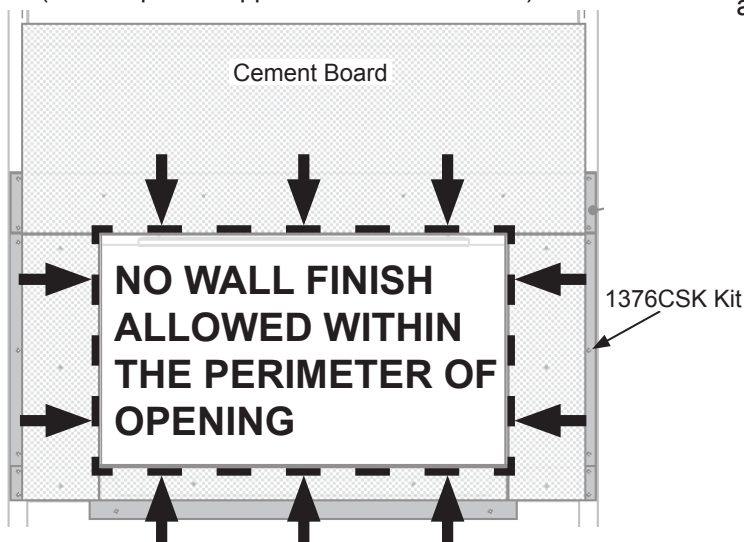

- Drywall (or combustible material) installs up to outside perimeter of cement board.
- Tile (or non-combustible material) may be installed overtop of cement board up to the appliance's opening.

Fixing the appliance to the framing

1. Screw the appliance to the floor or wood surface with 4 countersunk wood or cement screws (not provided).

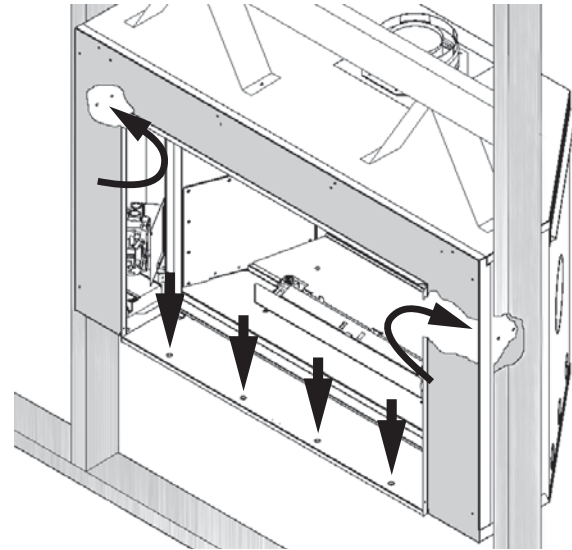

2. Screw the appliance to the side studs from the inside of the appliance case behind the side doors—1 screw each side.
NOTE: Fasteners may be adjusted later after the wall finish is completed and the trim or surround (if any) is applied.