



# retrofire



Patents Pending

## Direct Vent Fireplace Insert RF24IDN (NG) & RF24IDP (LPG)

### Installation and Owner's Manual

#### **WARNING**



**HOT GLASS WILL CAUSE BURNS.**  
**DO NOT TOUCH GLASS UNTIL COOLED.**  
**NEVER ALLOW CHILDREN TO TOUCH GLASS.**

**INSTALLER**  
Leave this manual with the appliance.

**CONSUMER**  
Retain this manual for future reference.

**WARNING:** If the information in these instructions is not followed exactly, a fire or explosion may result causing property damage, personal injury or loss of life.

Do not store or use gasoline or other flammable vapors and liquids in the vicinity of this or any other appliance.

#### WHAT TO DO IF YOU SMELL GAS

- Do not try to light the appliance.
- Do not touch any electrical switch; do not use any phone in your building.
- Immediately call your gas supplier from a neighbor's phone. Follow the gas supplier's instructions.
- If you cannot reach your gas supplier, call the fire department.

Installation and service must be performed by a qualified installer, service agency or the gas supplier.

Please read this manual **BEFORE** installing and operating this appliance.

This appliance may be installed in an after-market permanently located, manufactured (mobile) home where not prohibited by local codes.

This appliance is only for use with the type of gas indicated on the rating plate. This appliance is not convertible for use with other gases, unless a certified kit is used.

This appliance is a domestic room-heating appliance. It must not be used for any other purposes such as drying clothes, etc.

This appliance is suitable for installation in a bedroom or bed sitting room.

**Massachusetts:** The piping and final gas connection must be performed by a licensed plumber or gas fitter in the State of Massachusetts.

Ce guide est disponible en français sur demande.

Manufactured by  
**MILES INDUSTRIES LTD.**, British Columbia, Canada  
[www.valorfireplaces.com](http://www.valorfireplaces.com)

## Thank You ...

For purchasing a Valor Retrofire. Your new radiant gas heater is a technical appliance that must be installed by a qualified dealer. Each Retrofire is fully tested during the production process for your safety and comfort.

Your unit has been professionally installed by:

Dealer Name \_\_\_\_\_

Phone Number \_\_\_\_\_

**Should you encounter an operational problem, call your dealer immediately.  
Do not try to repair the unit as you may cause an injury or damage the fireplace.**

The information contained in this installation manual is believed to be correct at the time of printing. Miles Industries Ltd. reserves the right to change or modify any information or specifications without notice. Miles Industries Ltd. grants no warranty, implied or stated, for the installation or maintenance of your heater, and assumes no responsibility for any consequential damage(s).

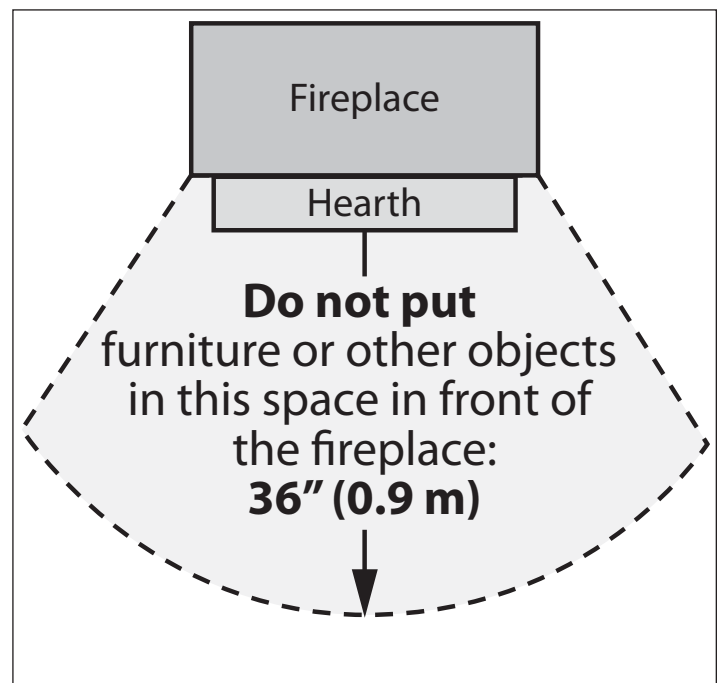

Designed and Manufactured by / for  
Miles Industries Ltd.

190-2255 Dollarton Highway, North Vancouver, BC, CANADA V7H 3B1

Tel. 604-984-3496 Fax 604-984-0246

[www.valorfireplaces.com](http://www.valorfireplaces.com)

© Copyright Miles Industries Ltd., 2011

# Safety and Your Fireplace

## Please Read and Carefully Follow all Safety Warnings and Operating Instructions Contained in Your Owners Manual

(Replacement Manuals are available by contacting our service department at 1-800-468-2567 or visit [www.valorfireplaces.com](http://www.valorfireplaces.com)).

### Please Follow These Important Child Safety Precautions and Recommendations,

- Parts of your Valor Fireplace become **extremely hot** while in operation.
- The glass viewing **window temperature can exceed 500 F** at full capacity. Momentary contact with a hot glass surface can **cause a severe burn**, even if the fireplace is operating at reduced heating capacity.
- **The glass window will remain hot** for an extended period of time after the fireplace has been turned off. Ensure that children are prevented from touching the fireplace during the cool down period.
- **Toddlers and Young Children must be closely supervised at all times** when they are in the same room as the operating fireplace. They lack full awareness of danger and rely on your protection. Toddlers, in particular, do not have the motor



skills and response reflexes to withdraw in the event of accidental contact with a hot surface.

- **A physical barrier is strongly recommended** if there are young children, or at-risk individuals in the house. Install an approved after-market safety gate to keep toddlers, young children and other at-risk individuals a safe distance from the fireplace.
- **Keep the remote control handset out of reach of children at all times.** A wall mount storage holster is provided with your remote control handset.
- **Ensure that the fireplace, including the pilot light, is completely turned off** when children are present and close supervision and safety barriers are not available—see page 23 of *Owner's Information* section.
- If the fireplace is not going to be used for the summer or any extended period of time, **remove the batteries from the remote control handset and receiver.** It is recommended that batteries are replaced annually in any event—see page 22.

# Table of Contents

<b>Safety and Your Fireplace .....</b>	<b>3</b>
<b>Safety and Warning Information.....</b>	<b>5</b>
◇ <b>Specifications .....</b>	<b>6</b>
<b>Dimensions .....</b>	<b>7</b>
<b>Vent Configurations.....</b>	<b>8</b>
<b>Vent Termination.....</b>	<b>9</b>
<b>Existing Fireplace Preparation .....</b>	<b>11</b>
<b>Supply Gas Installation .....</b>	<b>12</b>
<b>Vent Liner Rough-in.....</b>	<b>13</b>
<b>Appliance Preparation.....</b>	<b>13</b>
<b>Firebox Installation.....</b>	<b>14</b>
<b>Ceramic Fuel Bed Installation .....</b>	<b>16</b>
<b>Window Refitting and Checking.....</b>	<b>17</b>
<b>Remote Control Initial Set-up .....</b>	<b>18</b>
<b>Operation Check and Aeration Adjustment .....</b>	<b>18</b>
<b>Optional Cast Iron Fret Installation.....</b>	<b>19</b>
<b>Optional Bottom Cover Installation .....</b>	<b>19</b>
<b>Remote Control Handset Wall Holder Installation .....</b>	<b>20</b>
◇ <b>Owner's Information.....</b>	<b>21</b>
◇ <b>Remote Control Operation.....</b>	<b>24</b>
<b>Options .....</b>	<b>28</b>
<b>Lighting Instructions .....</b>	<b>29</b>
<b>Wiring Diagram .....</b>	<b>30</b>
◇ <b>Approved Venting Components .....</b>	<b>31</b>
<b>Warranty .....</b>	<b>32</b>
<b>Parts.....</b>	<b>33</b>

◇ = Updated content

**READ** and **UNDERSTAND** all instructions carefully before starting the installation. **FAILURE TO FOLLOW** these installation instructions may result in possible fire hazard and will void the warranty.

Prior to the first firing of the fireplace, **READ** the Owner's Information section of this manual.

**DO NOT USE** this appliance if any part has been under water. Immediately, **CALL** a qualified service technician to inspect the unit and to replace any part of the control system and any gas control that has been under water.

**THIS UNIT IS NOT FOR USE WITH SOLID FUEL.**

Installation and repair should be **PERFORMED** by a qualified service person. The appliance and venting system should be **INSPECTED** before initial use and at least annually by a professional service person. More frequent cleaning may be required due to excessive lint from carpeting, bedding, etc. It is **IMPERATIVE** that the unit's control compartment, burner, and circulating air passageways **BE KEPT CLEAN** to provide for adequate combustion and ventilation air.

Always **KEEP** the appliance clear and free from combustible materials, gasoline, and other flammable vapors and liquids.

**NEVER OBSTRUCT** the flow of combustion and ventilation air. Keep the front of the appliance **CLEAR** of all obstacles and materials for servicing and proper operation.

Due to the high temperature, the appliance should be **LOCATED** out of traffic areas and away from furniture and draperies. Clothing or flammable material **SHOULD NOT BE PLACED** on or near the appliance.

Children and adults should be **ALERTED** to the hazards of high surface temperature and should **STAY AWAY** to avoid burns or clothing ignition.

**YOUNG CHILDREN** should be **CAREFULLY SUPERVISED** when they are in the same room as the appliance. Toddlers, young children and others may be susceptible to **ACCIDENTAL CONTACT BURNS**. A physical barrier is recommended if there are at risk individuals in the house. To restrict access to a fireplace or stove, **INSTALL AN ADJUSTABLE SAFETY GATE** to keep toddlers, young children and other at risk individuals out of the room and away from hot surfaces.

This unit **MUST** be used with a vent system as described in this installation manual. **NO OTHER** vent system or components **MAY BE USED**.

This gas fireplace and vent assembly **MUST** be vented directly to the outside and **MUST NEVER** be attached to a chimney serving a separate solid fuel burning appliance. Each gas appliance **MUST USE** a separate vent system. Common vent systems are **PROHIBITED**.

**INSPECT** the external vent cap on a regular basis to make sure that no debris, plants, trees, shrubs are interfering with the air flow.

The glass door assembly **MUST** be in place and sealed before the unit can be placed into safe operation.

**DO NOT OPERATE** this appliance with the glass door removed, cracked, or broken. Replacement of the glass door should be performed by a licensed or qualified service person. **DO NOT** strike or slam the glass door.

The glass door assembly **SHALL ONLY** be replaced as a complete unit, as supplied by the fireplace manufacturer. **NO SUBSTITUTE** material may be used.

**DO NOT USE** abrasive cleaners on the glass door assembly. **DO NOT ATTEMPT** to clean the glass door when it is hot.

**TURN OFF** the gas before servicing this appliance. It is recommended that a qualified service technician perform an appliance check-up at the beginning of each heating season.

Any safety screen or guard removed for servicing **MUST BE REPLACED** before operating this appliance.

**DO NOT** place furniture or any other combustible household objects within 36" of the fireplace front.

**BE CAREFUL** not to put any decorating objects sensitive to heat to close above or around the fireplace as it gets very hot when operating.

**DO NOT** use this heater as a temporary source of heat during construction.

This appliance is a **DOMESTIC ROOM-HEATING APPLIANCE**. It must not be used for any other purposes such as drying clothes, etc.

**State of California. Proposition 65 Warning.** Fuels used in gas, wood-burning or oil fired appliances, and the products of combustion of such fuels, contain chemicals known to the State of California to cause cancer, birth defects and other reproductive harm. California Health & Safety Code Sec. 25249.6.

### Operating Your Fireplace for the First Time

When operating your new fireplace for the first time, some vapors may be released due to the burning of curing compounds used in the manufacture of the appliance. They may cause a slight odor and could cause the flames to be the full height of the firebox, or even slightly higher, for the first few hours of operation.

It is also possible that these vapors could set off any smoke detection alarms in the immediate vicinity. These vapors are quite normal on new appliances. We recommend opening a window to vent the room. After a few hours use, the vapors will have disappeared and the flames will be at their normal height.

## Specifications

This appliance is intended for installation **into existing masonry or factory-built, solid-fuel burning fireplaces only.**

### Approvals and Codes

This appliance is certified to ANSI Z21.88-2009 / CSA 2.33-2009 American National Standard / CSA Standard for *Vented Gas Fireplace Heaters* for use in Canada and the USA and to CGA 2.17-91 *High Altitude Standard in Canada*. This appliance is for direct vent installation terminating at the roof only.

**Model RF24IDN** is for use with Natural Gas only.

**Model RF24IDP** is for use with LPG only.

Conversion between fuels may only be done using the approved conversion kits listed in the section *Options*.

This appliance complies with CSA P4.1-09 *Testing method for measuring annual fireplace efficiencies*.

The installation must conform to local codes or, in the absence of local codes with the *National Fuel Gas Code, ANSI Z223.1* or the *Canadian Installation Code CAN/CGA-B149*. Only qualified licensed or trained personnel should install this appliance.

This appliance, when installed, must be electrically grounded in accordance with local codes, or in the absence of local codes, with the *National Electrical Code, ANSI/NFPA 70* or the *Canadian Electrical Code, CSA C22.1*

### Ratings

Model	NG	LPG
Gas	Natural	Propane
Altitude (Ft.)*	0-4,500 feet*	
Input Maximum (Btu/h)	24,000	24,000
Input Minimum (Btu/h)	10,500	10,500
Manifold Pressure (in w.c.)	3.95	9.5
Minimum Supply Pressure (in w.c.)	5.0	11.0
Maximum Supply Pressure (in w.c.)	10.5	14.0
Main Burner Injector Marking	82-580	92-260
Pilot Injector Marking	51	30

### \*High Altitude Installations

Input ratings are shown in BTU per hour and are certified without deration for elevations up to 4,500 feet (1,370 m) above sea level.

For elevations above 4,500 feet (1,370 m) in USA, installations must be in accordance with the current ANSI Z223.1 and/or local codes having jurisdiction.

In Canada, please consult provincial and/or local authorities having jurisdiction for installations at elevations above 4,500 feet (1,370 m).

### WARNING

**Some materials or items, although safe, may discolor, shrink, warp, crack, peel, and so on because of the heat produced by the fireplace. Avoid placing candles, paintings, photos, and other items sensitive to heat around the fireplace.**

### WARNING

**HOT HEARTH / FLOOR! The hearth or floor in front of the fireplace may become very hot when the fireplace heats. Do not use the hearth as a seat or shelf. Solid wood flooring in front of the fireplace (if allowed) may shrink during the heating season due to heat.**

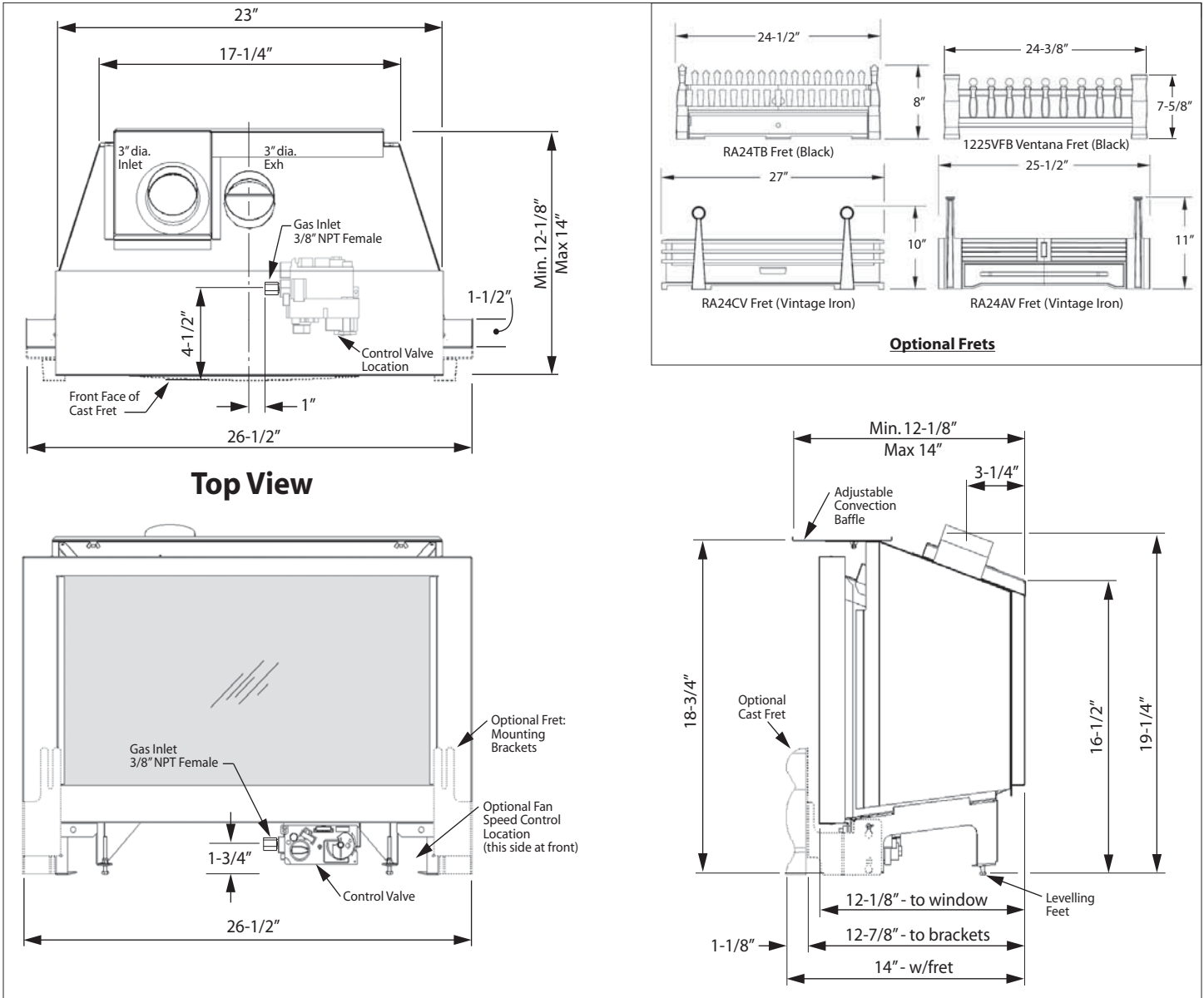

**Minimum Cavity Dimensions**

The diagram shows minimum dimensions required to install the RF24. Cavities having a combination of all the minimum dimensions shown, although possible, may prove to be difficult installations.

**Important:** A free space of 3/4 inch (19 mm) is required in front of the window to allow the window to move and relieve during a hard start. The use of the optional fret sets this space with the fret bracket installed.

However, when the fret is not used and the bottom cover is used instead, this space must be added to the depth as a safety precaution. **It is very important to ensure that the area immediately in front of the window is kept clear at all times even when not using a fret.**

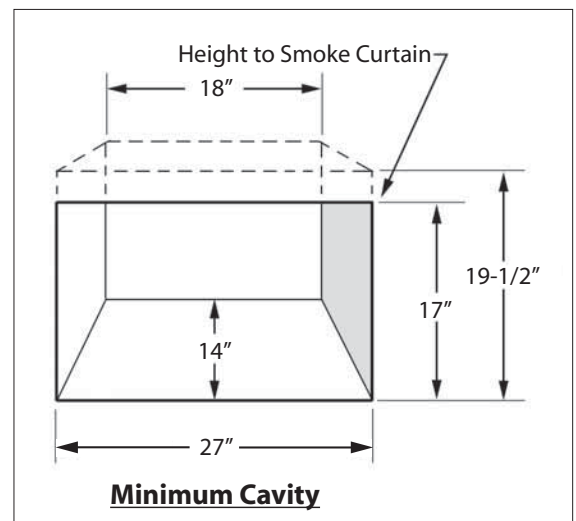

# Vent Configurations

## Allowable Vent Configurations

The RF24 is certified for use with approved 3" diameter flexible venting installed into an approved existing solid fuel burning masonry or factory built chimney system. The venting system must terminate vertically at the roof using an approved termination cap. Both inlet and exhaust liners must be run continuously from appliance to roof termination.

Where possible, avoid joints in flex pipe. If joints are required, use only connectors approved by the manufacturer of the flex pipe. Field fabricated joints are not allowed.

Any generic 3" diameter flexible venting **approved for venting gas appliances** is acceptable. See list of the approved venting components on page 31 of this manual.

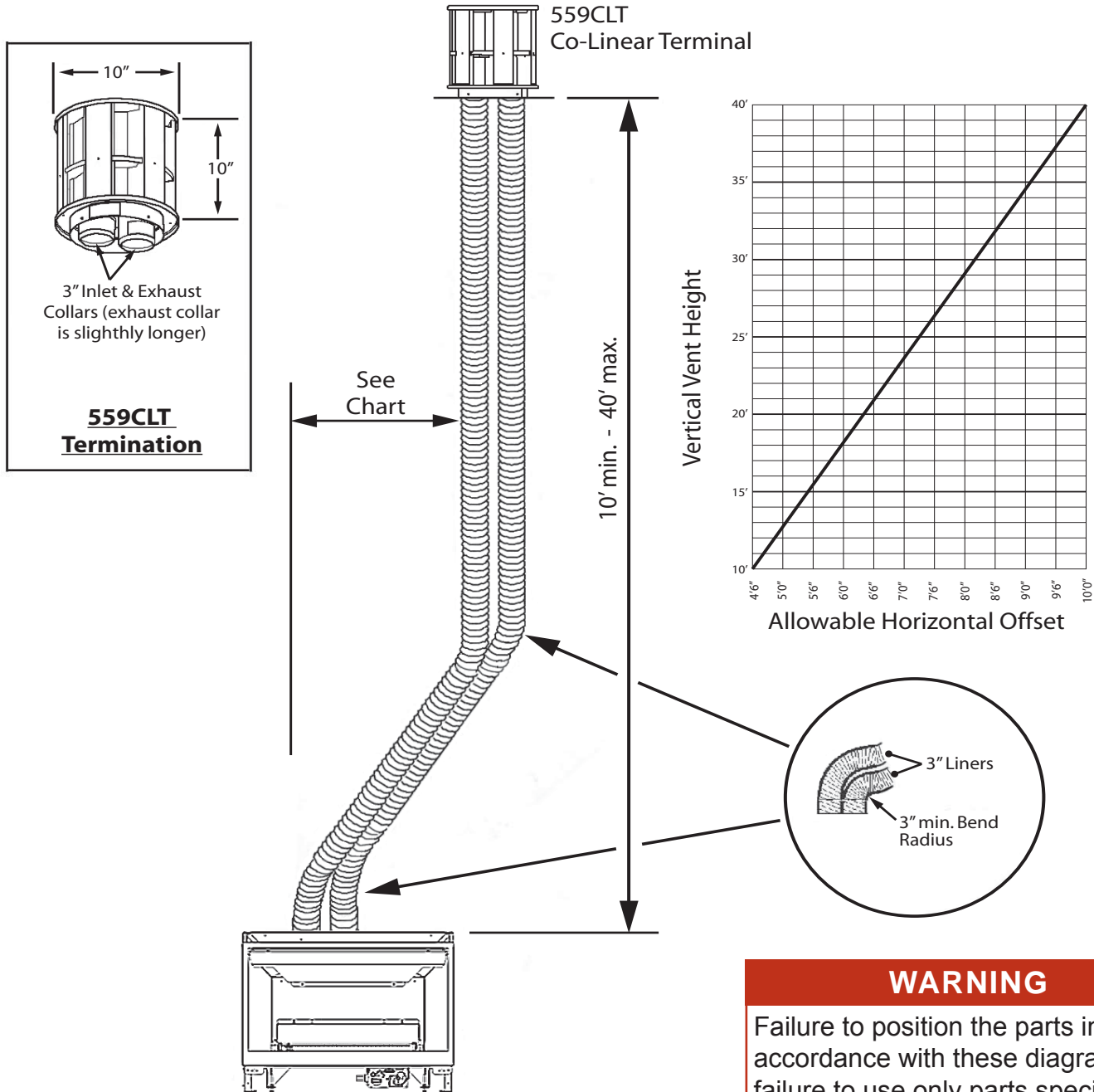

**WARNING**

Failure to position the parts in accordance with these diagrams or failure to use only parts specifically approved with this appliance may result in property damage or personal injury.

The RF24 is approved for **Vertical Co-Linear Termination Only**. Two 3" diameter liners are required from top to bottom. The vent liners must be connected to the proper collars (intake and exhaust) or the unit will not operate properly. The method of flashing will depend on whether the liners are installed into a rectangular masonry or round factory-built solid-fuel burning chimney. **It is important to seal the gap at the top of the chimney in either case to avoid convective air loss up the chimney.** The integrity of the air-cooled function of factory-built chimney systems must be maintained when installing terminations. **Termination of the chimney may need to be completed after the RF24 firebox is installed and the slack vent liner pulled up—see section *Firebox Installation*.**

### Existing Square Chimneys

**559CLT** Co-Linear Terminal and **559SFK** Square Flashing Kit are recommended—see list of approved venting accessories on page 31. Cut flashing kit to size. Allow extra around perimeter for drip edge to be formed on site. Seal flashing to top of chimney using sealant (not supplied). Fasten terminal to flashing using sheet metal screws as shown.

### Existing Round Factory-Built Chimneys

The 559CLT terminal is designed to fit existing 7" or 8" diameter factory-built round chimneys without requiring additional flashing. Ensure the installation of the terminal seals off the top of the chimney space to avoid convective air loss. The diagrams below show a typical terminal installation for an 8" diameter air-cooled chimney system.

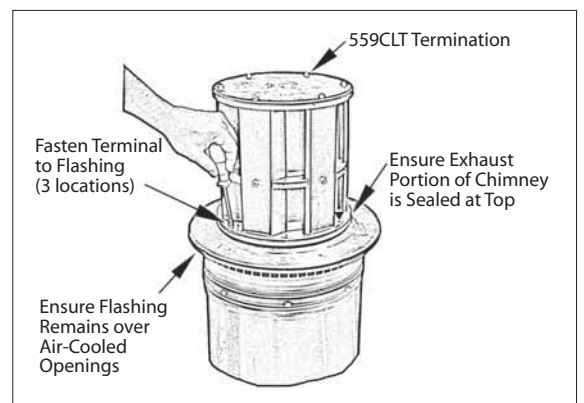
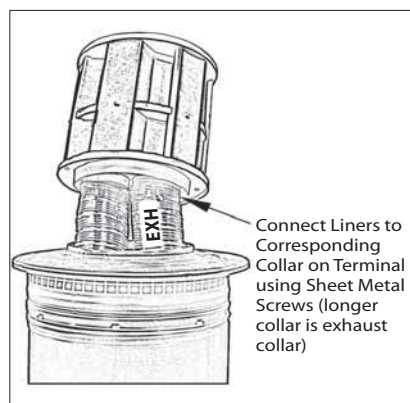
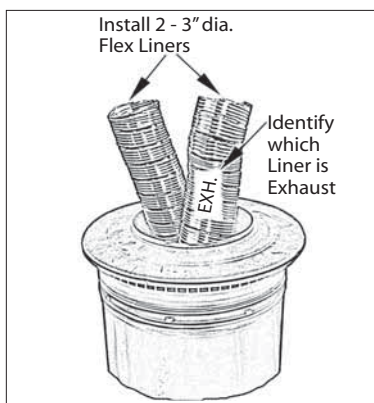
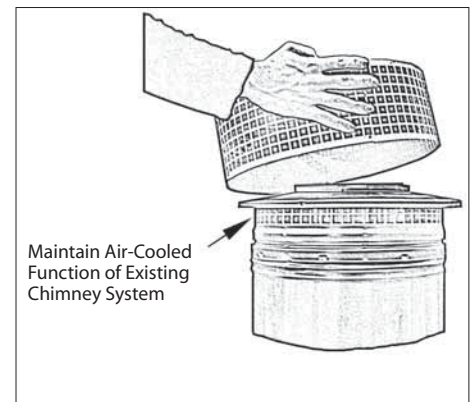
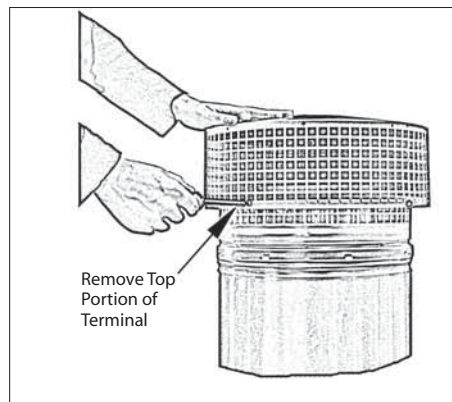
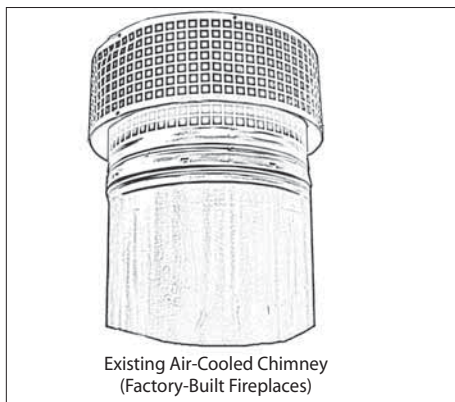
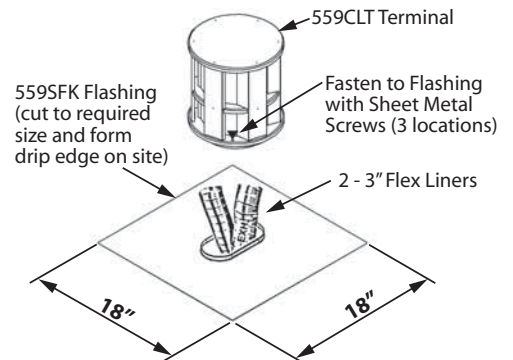
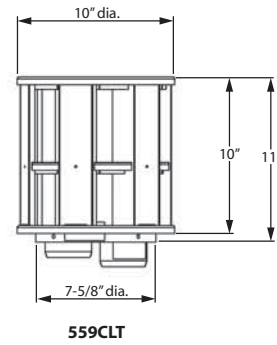

**Vent Terminal Location**

The venting system for this appliance is considered to be a **Special Venting System**. The rule in the Installation Code CAN/CGA-B149 requiring a minimum vent height of 2 feet above any portion of a building within 10 feet does not, therefore, apply.

**Clearances for Vent Terminal**

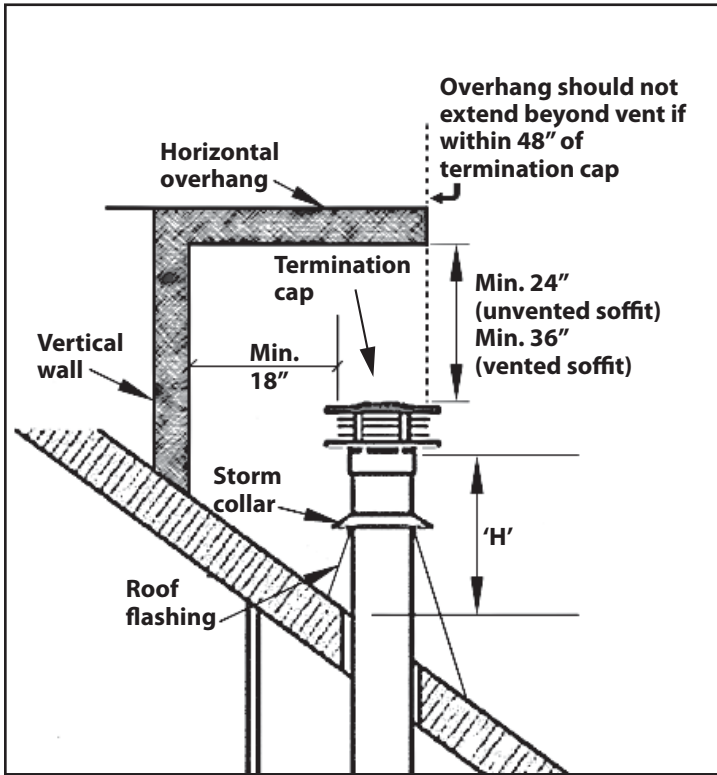

Roof Pitch	Minimum 'H' (feet)
Flat to 7/12	1'
over 7/12 to 8/12	1.5'
over 8/12 to 9/12	2'
over 9/12 to 10/12	2.5'
over 10/12 to 11/12	3.25'
over 11/12 to 12/12	4'
over 12/12 to 14/12	5'

A few points must be considered before inserting the RF24 into an existing fireplace cavity. Generally, no modifications are allowed to the existing fireplace that will compromise the integrity of the existing fireplace. Components that are bolted or screwed on such as dampers or baffles may be removed to accommodate the installation of the RF24 engine. **Cutting away any sheet metal parts of the existing fireplace to accommodate the installation of the RF24 is prohibited.** Check with local authorities if in doubt.

### Clean Fireplace and Chimney

Have the chimney swept and the fireplace cavity including ash dumps and clean-outs cleaned before installing the RF24 heater and vent liners. Any creosote or soot residue remaining in the fireplace cavity, chimney, or clean-out may cause odors or stains once the RF24 insert is installed. Consult with chimney sweep for information on how best to clean.

### Existing Dampers

Factory-built, zero-clearance fireplaces will require the damper to be removed in order to install the vent liners. These dampers are usually bolted into place. Dampers in masonry fireplaces must be fixed open and may remain in place.

### Ash Retaining Curbs

Some fireplaces (particularly factory-built) have a raised curb at the front edge to retain ashes. Check the dimensions carefully to ensure the RF24 engine will fit behind any raised curb (some curbs may be removed separately from the refractory base). The fret retainers allow for some vertical adjustment of the cast iron fret should the fret need to sit on top of the curb, otherwise the fret will need to be eliminated or adequate room provided behind the curb.

### Gas Line Routing

Plan the routing of the gas line before proceeding. Utilize the existing hole for the gas line. If the factory-built fireplace has no access hole, carefully drill an access hole of 1.5 inch (38 mm) or less through the lower sides or bottom of the firebox. The access hole must be plugged with non-combustible insulation after the gas supply line has been installed. See General Dimension drawing for detailed location of gas inlet. Also, take into consideration whether or not a fan or shut-off valve will interfere when planning routing of the gas line.

### Existing Glass Doors and Wire Screens

**Existing glass doors must be permanently removed** prior to installing the RF24 insert. Existing wire fire screens may remain in place or new ones may be added. The RF24 has been tested and approved to operate with wire fire screens in the closed or open positions.

### Combustible Mantels

Combustible mantel clearances must conform to those required for the original solid-fuel fireplace into which the RF24 is being installed.

### Paint Existing Refractory Liners

It may be desirable, for visual reasons, to paint the existing refractory liners in black to blend in with the RF24 insert once installed.

### Attach Warning Label to Existing Fireplace (label supplied loose with RF24 heater)

Attach the "This fireplace has been converted..." label to the existing fireplace using screws or other mechanical means and store any removed parts in back of the existing fireplace for future use.

## Supply Gas Installation

- It's preferable to rough-in the gas line at this point before proceeding with the firebox installation.
  - The gas supply inlet connection is a 3/8" NPT female connector. For detailed location of this connector, see drawing in section *Dimensions*. If a circulating fan or isolating valve is to be installed, adjust the routing of the gas line to suit.
  - Use only new black iron or steel pipes or copper tubing if acceptable—check local codes. Note that in USA, copper tubing must be internally tinned for protection against sulfur compounds.
  - Unions in gas lines should be of ground joint type.
  - The gas supply line must be sized and installed to provide a supply of gas sufficient to meet the maximum demand of the appliance without undue loss of pressure.
  - Sealant used must be resistant to the action of all gas constituents including LP gas. Sealant should be applied lightly to male threads to ensure excess sealant does not enter gas lines.
  - The supply line should include a manual shut-off valve and union to allow the appliance to be disconnected for servicing.
  - Pressure test the supply line for leaks.
  - The appliance and its individual shut-off valve must be disconnected from the gas supply piping system during any pressure testing of that system at test pressures in excess of ½ psig (3.5 kPa).
  - The appliance must be isolated from the gas supply piping system by closing its individual manual shut-off valve during any pressure testing of the gas supply piping system at test pressures equal to or less than ½ psig (3.5 kPa).
  - Failure to either disconnect or isolate the appliance during pressure testing may result in regulator or valve damage. Consult your dealer in this case.
  - The minimum supply pressure is given in the section *Specifications* of this manual.
  - All piping and connections must be tested for leaks after installation or servicing. All leaks must be corrected immediately.
- When testing for leaks:
    - Make sure that the appliance is turned off.
    - Open the manual shut-off valve.
    - Test for leaks by applying a liquid detergent or soap solution to all joints. Bubbles forming indicate a gas leak. **Never use an open flame to check for leaks.**
    - Correct any leak detected immediately.
  - The pressure test tapping locations are shown in figure below. A built-in non-adjustable regulator controls the burner manifold pressure. The correct pressure range is shown in the table in section *Specifications* of this manual. The pressure check should be made with the burner alight and at its highest setting. See *Lighting Instructions* section for full operating details.

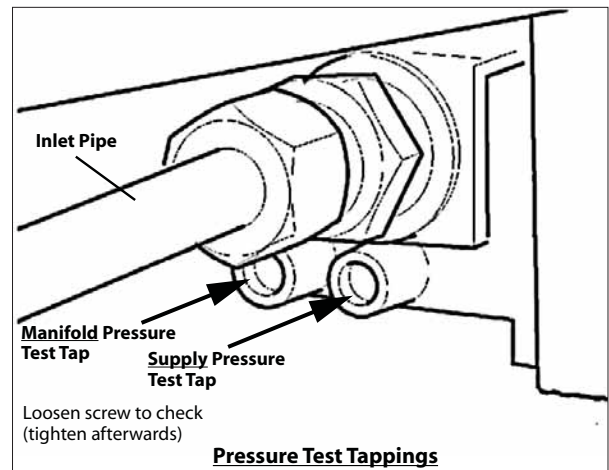

Rough-in the two 3" diameter vent liners into existing chimney system being careful not to tear or damage the liners in the process. It may be easier to install both liners at the same time rather than one at a time. Leave plenty of liner at the bottom end if the heater will be connected while on the hearth (see diagram).

When connecting the liner in this manner **it is best to leave the top termination until later** so the slack liner can be lifted after the insert is in place (see separate section for top termination). **Designate and mark the top and bottom of one liner as "EXHAUST" to avoid confusion later.**

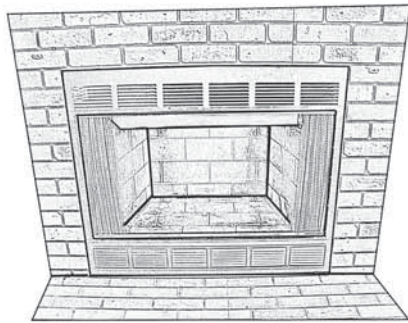

**Existing Fireplace**

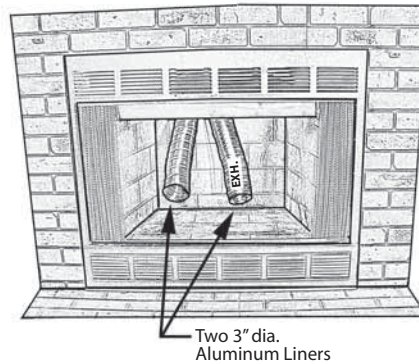

**Rough-In Liners**

## Appliance Preparation

The size of the existing fireplace cavity will affect the method of installation. Smaller fireplaces, particularly factory-built zero-clearance fireplaces will require the RF24 firebox to be disassembled then reassembled inside the fireplace. Plan your particular installation accordingly.

1. Unpack appliance.
2. Remove window.
3. Remove log pack from firebox.
4. Strip firebox down by removing:
  - a. Burner Module (10 screws),
  - b. Support Legs (2 screws per leg) (required when inserting into small fireplaces only)

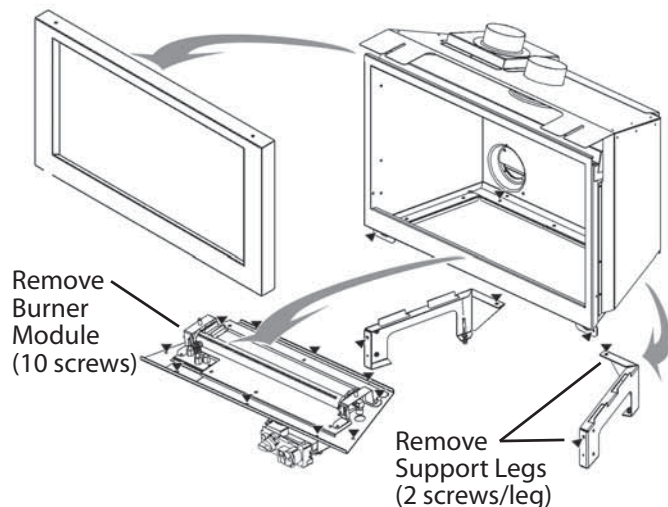
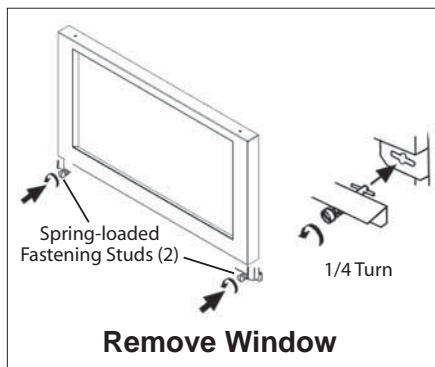

**Connection of liners to firebox**

Trim liners if necessary and connect to the firebox either while the firebox is on the hearth (Option 1) or with the firebox in the cavity (Option 2). Use gear clamps provided to connect the liners to the firebox.

If the liners are connected with the firebox on the hearth, it will be necessary to pull the slack liner up from the top of the chimney after the firebox is installed.

**Option 1 - Connect liners with firebox on hearth**

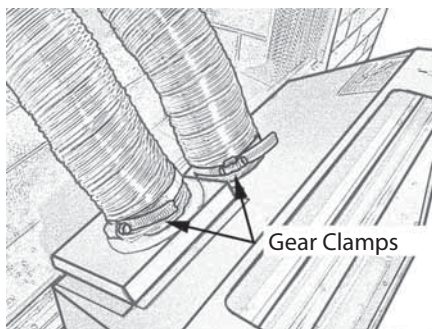
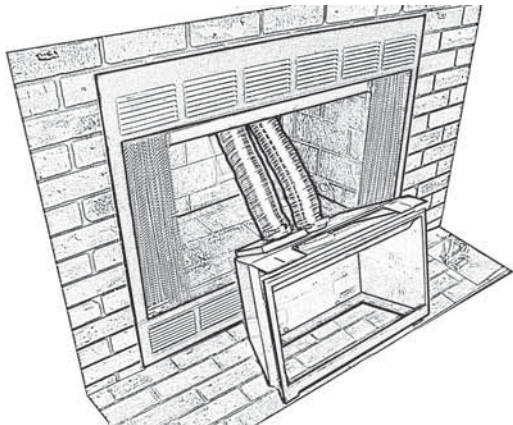

**Option 2 - Connect liners in fireplace**

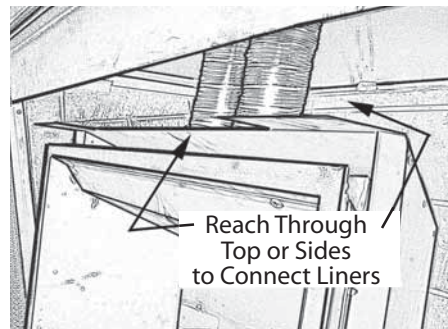
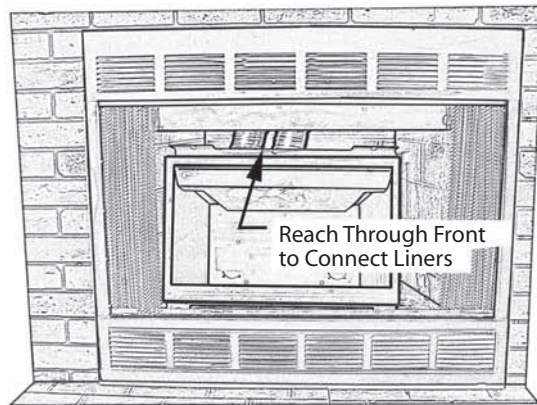

**Support Legs Reinstallation (if removed)**

With the firebox recessed behind the smoke curtain of the existing fireplace, raise the firebox and place the individual support legs under the firebox. Placing a temporary shim under the firebox, such as a 2" x 4",

may help while positioning the support legs. Tabs are provided on the support legs to help position them. Fasten the support legs at the points indicated by the arrows using the bolts provided (2 per side).

Thread thumbscrews into support leg. Raise right side of firebox and slip RH support leg under. Fasten with 2 bolts as indicated.

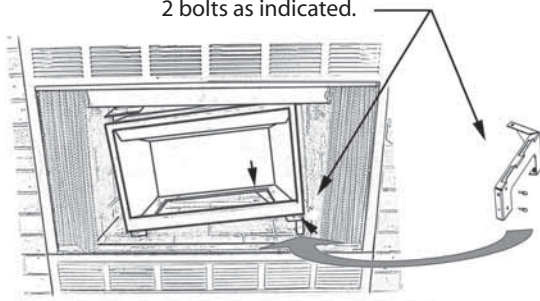

Thread thumbscrews into support leg. Raise left hand side of firebox and slip LH support leg under. Fasten with 2 bolts as indicated.

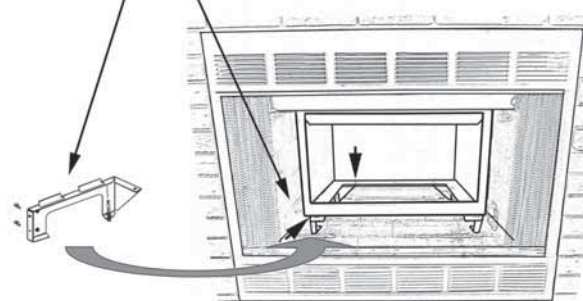

### Leveling the firebox in the hearth

The backside of each support leg has a leveling bolt. If necessary, adjust the level of the firebox in the hearth.

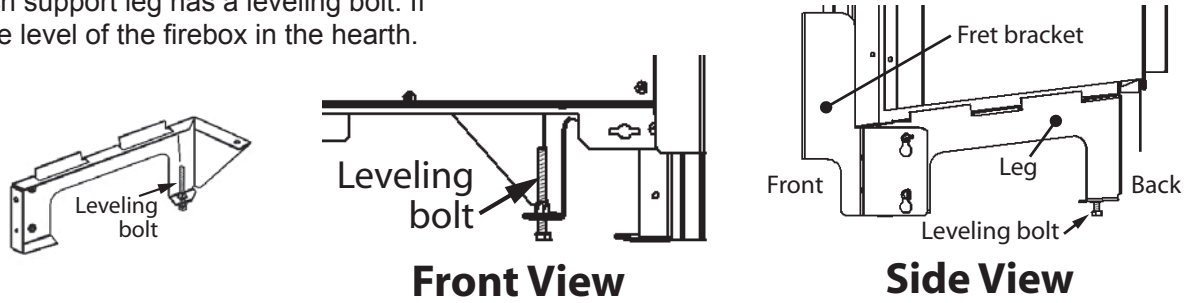

### Burner Module Reinstallation

**Note:** If the circulating fan is to be installed it should be done at this point before installing the burner module. See instructions packaged with the fan for details of the fan installation.

Reinstall the burner module using the 10 screws removed previously.

**Note:** The upper baffle may be removed to gain more room for the screwdriver to install the rear screws.

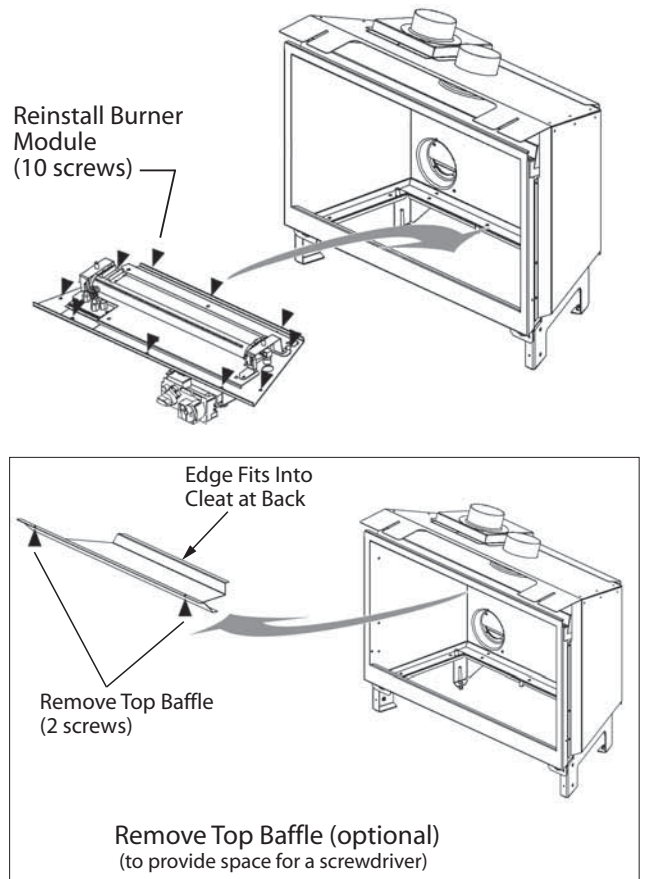

### Gas Line Connection and Fire Unit Testing

Connect the gas line to the burner module. Check for leaks, purge the line, and test-fire the unit before installing the window or proceeding with the remainder of the install—see section *Lighting Instructions*.

### Top Baffle Reinstallation (if removed)

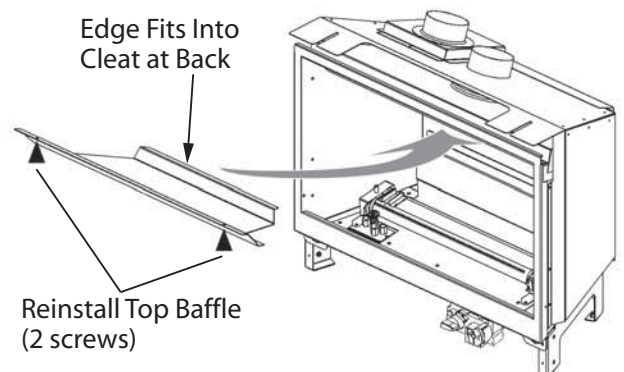

# Firebox Installation

## Top Convection Baffle Installation

Position the firebox as far back as possible within the existing fireplace to allow ample space at front for the fret and to allow convection air to flow under the smoke curtain of the existing fireplace.

Position the top convection baffle with the threaded studs pointing downwards into the slots at the top of the firebox. Slide the convection baffle as far forward as possible, angled down if possible, to force the air under the smoke curtain, and tighten the wing nuts.

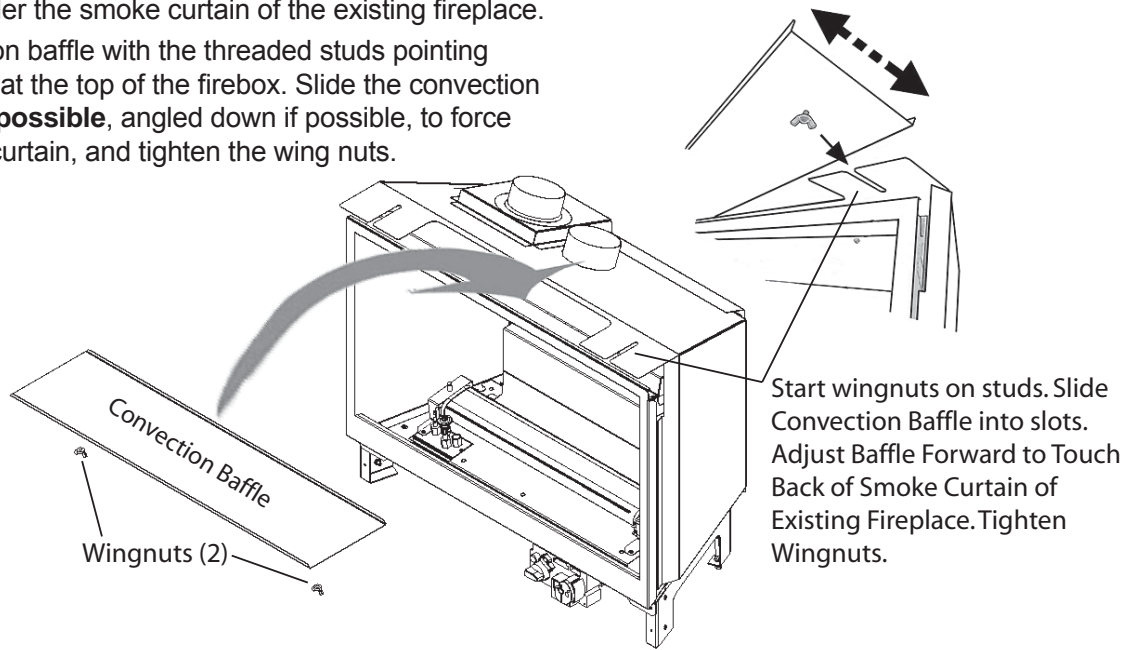

## Ceramic Fuel Bed Installation

### Ceramic Log Set Installation

Carefully remove the ceramic logs from the packaging taking care not to damage them. Install the logs as described below.

**Please note that the Rear Log will have a different position depending of the gas type.**

***The position of the logs is critical to insure the good performance of the appliance.***

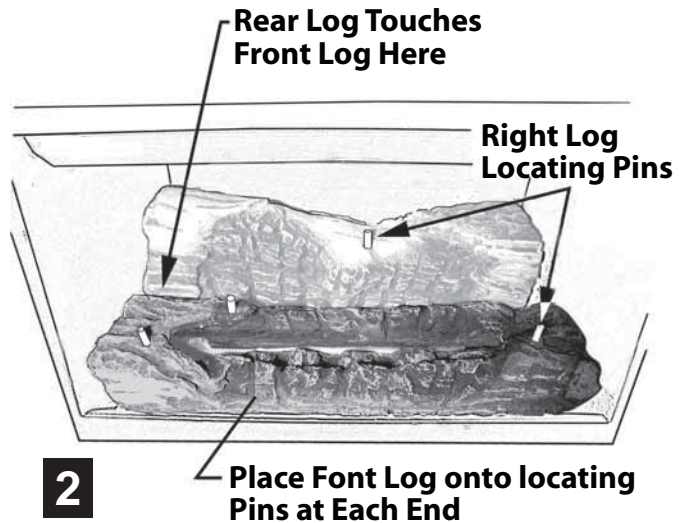
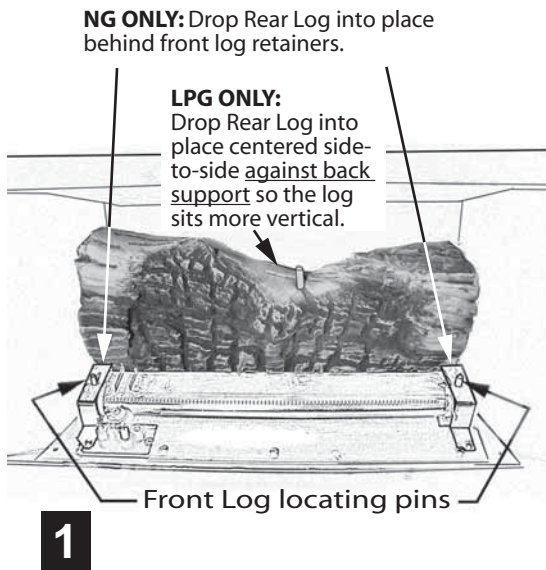

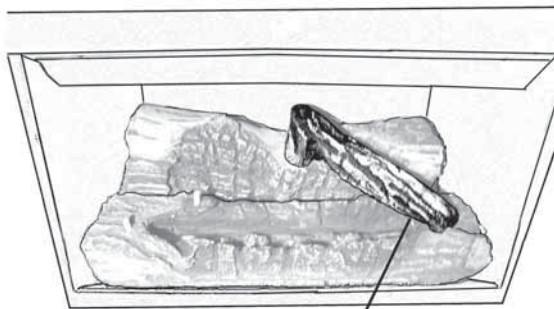

Place R/H Cross Log  
Onto Locating Pins

**3**

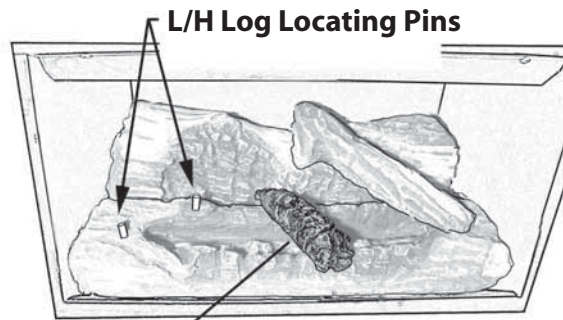

Place Middle Cross Log  
Across Gap in Front Log

**4**

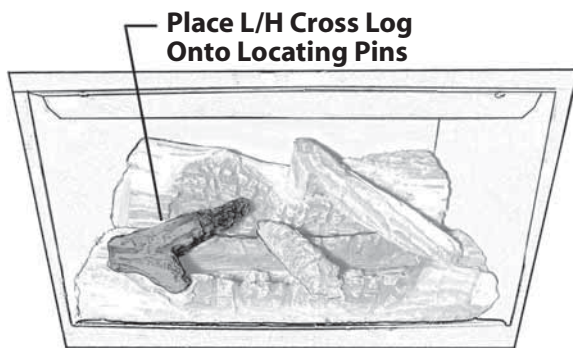

Place L/H Cross Log  
Onto Locating Pins

**5**

## Window Refitting and Checking

Hook the window over the top edge of the firebox, and fasten the bottom two spring loaded bolts by pushing in and turning 90 degrees. Check that the window moves freely against the spring by pulling out at the bottom. If broken, the window may only be replaced as a complete unit as supplied by the manufacturer.

**Note:** To remove the window, the optional bottom cover or the cast iron fret and fret retainers will need to be removed first—see sections *Optional Cast Iron Fret Installation* or *Optional Bottom Cover Installation*.

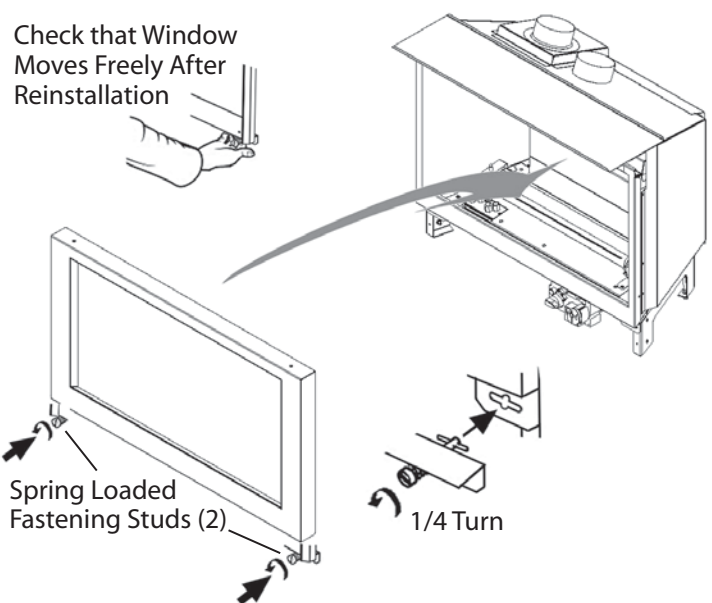

## Remote Control Initial Set-up

The receiver and the handset of the remote control system must be initially synchronized before the first use.

1. Insert alkaline batteries in the remote control receiver and handset. The receiver is located left of the control valve under the burner module.
2. With a sharp object, press and hold the receiver's reset button until you hear one short and one long beeps. Release the reset button after the second beep.
3. Within the subsequent 20 seconds, press the small flame button (  ) on the remote handset until you hear two short beeps confirming the synchronization is set.

This is a one time setting only and is not required when changing the batteries in the remote receiver. The remote control system is now ready to use.

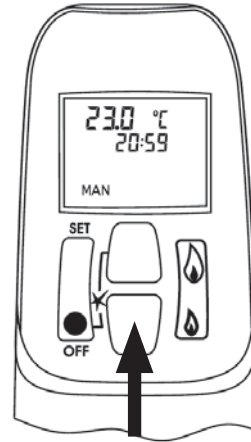
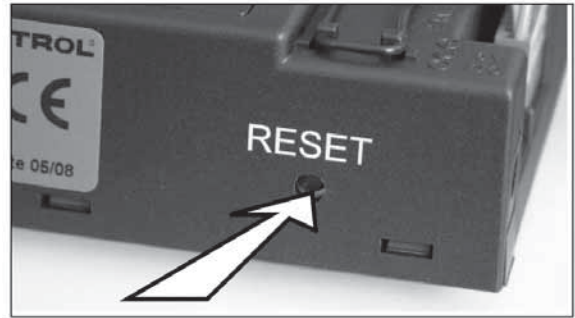

## Operation Check and Aeration Adjustment

Turn the fireplace up and down using the remote control to confirm that the full range of inputs is achieved.

Light the fire and allow to warm up for 10–15 minutes to evaluate the flame picture. The burner is equipped with an adjustable air shutter to control primary aeration. See figures below. The shutter is factory-set at an aeration gap, which will give optimum performance for the vast majority of installations. In a few unusual installations, flame picture may be improved by adjusting the aeration. The need for adjustment should be determined only by operating the appliance with the ceramic fuel effects and window installed.

**Increasing aeration** will cause the flame to appear more transparent and blue making the ceramic fuel effects glow more.

**Decreasing aeration** will cause the flames to appear more yellow or orange making the fuel effects glow less.

**Too little aeration may result in black carbon forming and dropping into the firebox.**

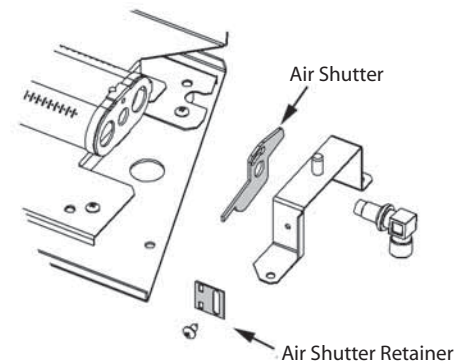

**Air Shutter Components**

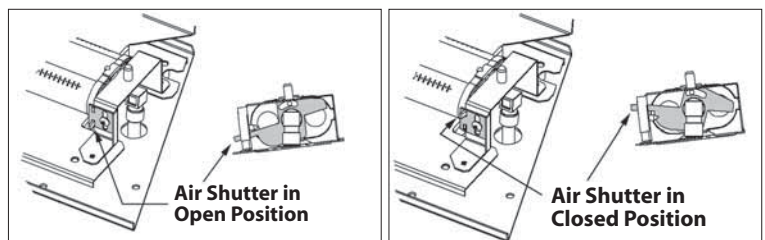

**Important:** The fret retainer brackets are designed to maintain the required space in front of the window to allow the window to move and relieve during a hard start. ***It is very important to ensure this area in front of the window is kept clear at all times.***

### Fret Retainer Brackets Installation

Screw 2 thumbscrews into sides of each support leg if not done previously when support legs were installed. Fit the slotted holes in the fret retainers over the thumbscrews, push fret retainers downwards and tighten screws.

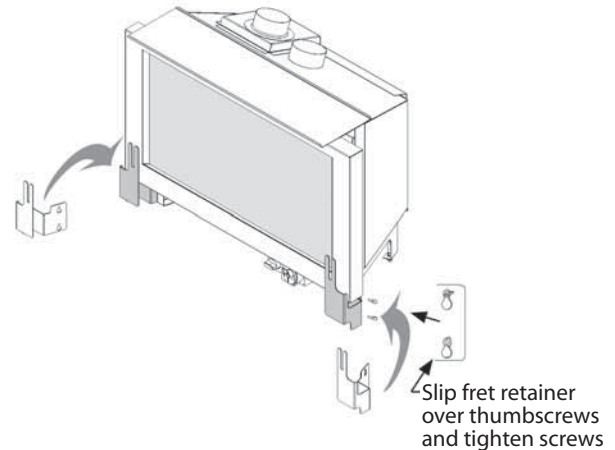

### Cast Iron Fret Installation

Adjust screw heads on back of fret to the thickness of the retainer bracket and drop the fret into place while guiding the screw heads into the slots in the bracket. Clip the ash pan cover onto the fret.

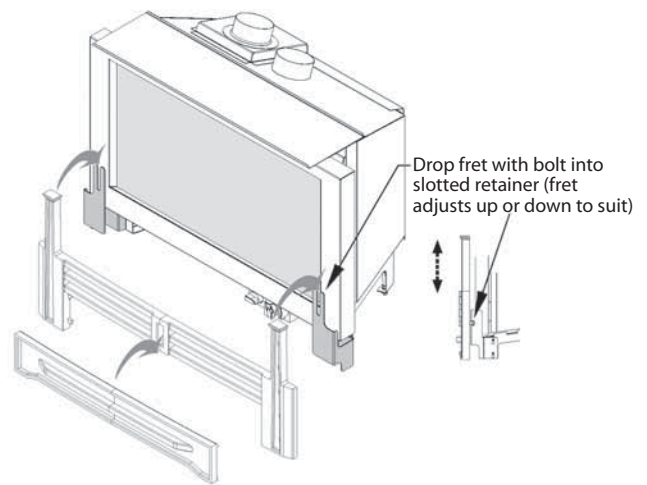

# Optional Bottom Cover Installation

**Important:** When the bottom cover is used instead of a fret, a space is required in front of the window to allow the window to move and relieve during a hard start. ***It is therefore very important to ensure that an area of 3/4 inch (19 mm) in front of the window is kept clear at all times.***

Hook the upper flange of the bottom cover onto the window bolts.

Rear View

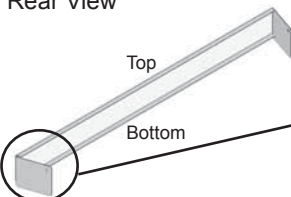

Side View

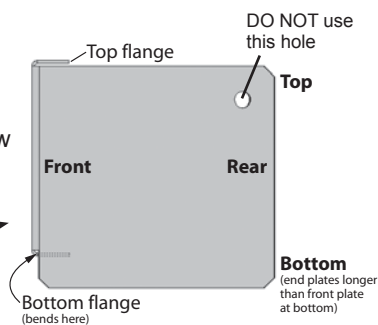

**An area of 3/4 inch (19 mm) in front of the window MUST be kept clear at all times!**

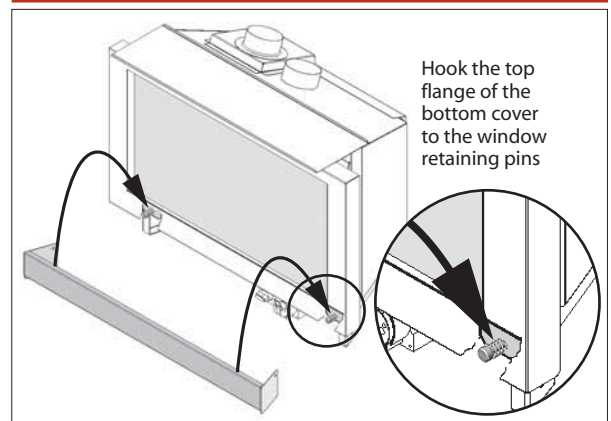

## INSTALLATION Remote Control Handset Wall Holder Installation

The remote control kit for this fireplace comes complete with a wall-mounted holder. This holder is not required in all installations but is provided as an optional feature for those customers who wish to mount the remote handset to the wall.

To install the holder to the wall, find a convenient location and use the hardware provided with the kit. See the diagram below for required hardware and configurations. Note that the holder can be installed at the base of a light switch plate.

**IMPORTANT.** The location of the remote control handset is important to assure proper temperature regulation. To obtain a constant temperature, we recommend that the handset should be between 3 and 15 feet away from the appliance **but not directly above it**. We also advise that the handset should be located away from any other heat source and not in direct sunlight as this may affect the temperature sensor located in the remote handset.

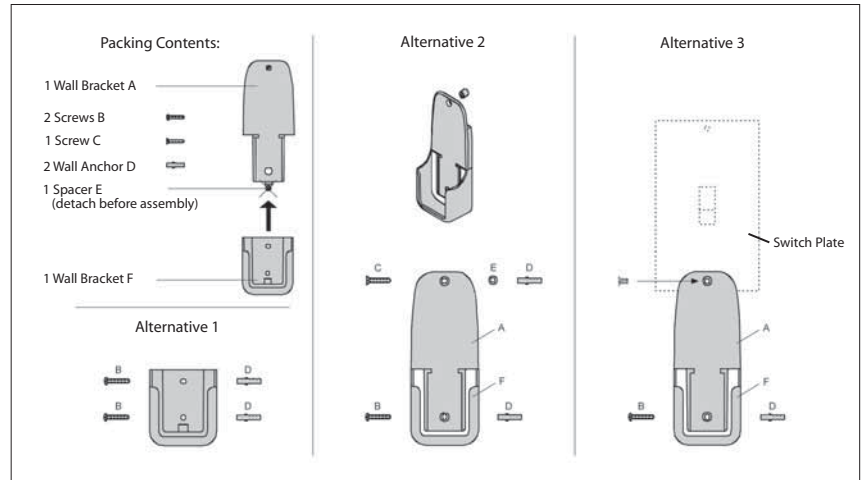

**WARNING**

**EXTREMELY HOT!!!**

- Some parts of your fireplace are **EXTREMELY HOT**, particularly the window.
- **DO NOT LET CHILDREN** touch the glass or any parts of your fireplace even after it is turned off as it is still hot.
- **USE A SAFETY SCREEN or a GATE** to reduce the risk of burns.
- Keep the remote control handset **OUT OF REACH** of children.
- Some materials or items, although safe, may discolor, shrink, warp, crack, peel, and so on because of the heat produced by the fireplace. **AVOID PLACING** candles, paintings, photos, and other items **SENSITIVE TO HEAT** within 36 inches (0.9 m) around the fireplace.
- **HOT HEARTH / FLOOR!** The hearth or floor in front of the fireplace may become very hot when the fireplace heats. Do not use the hearth as a seat or shelf. Solid wood flooring in front of the fireplace (if allowed) may shrink during the heating season due to heat.

Performance of LPG appliances may be affected by the quality of commercial gas supplied in your area.

Warranty Card at the back of this manual.

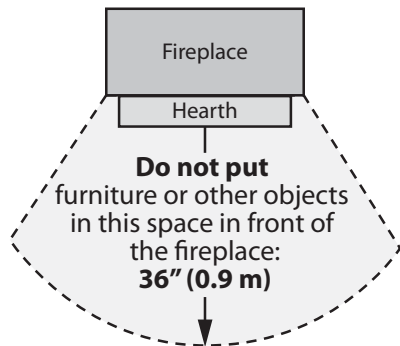

Please read the safety information on pages 3 and 5 of this manual.

**Operating Your Fire**

For your safety, this appliance is fitted with a flame supervision device which will shut-off the gas supply if, for any reason, the pilot flame goes out. This device incorporates a fixed probe, which senses the heat from the pilot flame. If the probe is cool, the device will prevent any gas flow unless manually lighting the pilot. See full lighting instructions on page 29 of this manual.

**Cleaning**

**WARNING**

**DO NOT TOUCH THE GLASS WHILE IT IS HOT!**  
Let the fireplace cool first before cleaning it.

**Important - Glass cleaning - Mineral deposits**

One of the by-products of the combustion process in a gas appliance is a mineral which can show up as a white film on the ceramic glass of the viewing door.

The composition of the deposit varies widely from various locations and also from time to time in the same location. It seems this is associated with the varying sulfur content of the gas. You may have the problem for a time and then not see it for many months when it will reappear in your area.

We have discussed this problem with ceramic glass manufacturers and they cannot give us a definitive answer to this problem. Dealers have tried various cleaning products with varying results. The following recommendations will not guarantee results in your particular case.

**NOTE: This is a problem beyond Miles Industries' control and is not covered under warranty.**

- Clean the glass regularly as soon as you notice the buildup (white film). If the film is left for a longer period of time, it will bake on. It is then much harder, if not impossible, to remove.
- NEVER use an abrasive cleaner on the ceramic glass. Any abrasion of the surface has the immediate effect of compromising the strength of the glass. An emulsion type cleaner is recommended.
- Use a soft damp cloth to apply the cleaner. Dry the glass with a soft, dry, preferably cotton cloth. Most paper towels and synthetic materials are abrasive to ceramic glass and should be avoided.
- Our dealers have had good results from the products listed below. We cannot, however, guarantee the results of these products.
  - » BRASSO, POLISH PLUS by KELKEM, COOK TOP CLEAN CREME by ELCO, WHITE OFF by RUTLAND, TURTLE WAX

**Do not clean the glass while it is hot.**

Always securely replace the window before lighting. **If broken, the glass pane may only be replaced as a complete window unit as supplied by the manufacturer.**

**WARNING****DO NOT TOUCH THE GLASS WHILE IT IS HOT!**

Let the fireplace cool first before cleaning it.

It is necessary to remove the cast iron fret and brackets or the bottom cover before removing the window—see previous installation sections.

The window can be removed for cleaning by rotating the two fastening studs at the bottom corners 90 degrees to release, and swinging the bottom of the window unit outwards to unhook the top edge.

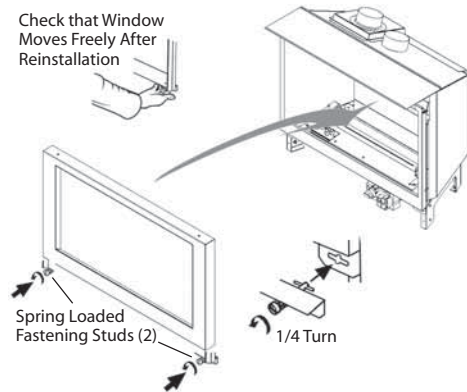

After refitting the window, apply light hand pressure against the window frame sides to bed-in the window seal.

Dust, etc. can be brushed from the ceramic fuel effects and firebox walls after removing the front unit and opening the window. Dust etc. can also be removed from the burner using a soft brush after removing the ceramic fuel effects. **When cleaning, make sure that no particles are brushed into the slots in the burner.**

**Checks**

A periodic check of the pilot and burner flames should be made. Check after the fire has been on for at least 30 minutes. The pilot flame must cover the tip of the thermocouple probe. The main burner flame pattern will vary from appliance to appliance depending on the type of installation and climatic conditions—see images below.

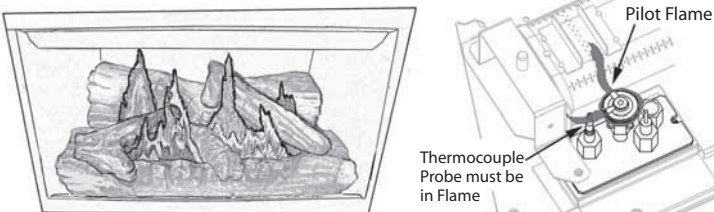
**Correct Flame Picture**

The appliance area must always be kept clear and free from combustible materials, gasoline and other flammable vapors and liquids.

Inspect the vent terminal outdoors regularly to make sure that, snow, leaves, bushes, trees, etc, do not obstruct it.

Examine the vent system and terminal regularly. We recommend annually.

**Batteries****WARNING**

**DO NOT ATTEMPT TO CHANGE THE BATTERIES WHILE THE FIREPLACE IS STILL HOT!** Let the fireplace cool first before touching it.

**CAUTION**

**DO NOT USE** a screwdriver or other metallic object to remove the batteries from the receiver or the handset! This could cause a short circuit to the receiver.

**Low batteries signal: see page 28.**

**BEFORE** changing the batteries, turn off the valve using the manual On/Off switch—see instructions on the following page.

The appliance uses four alkaline 1.5 V AA batteries for its remote control receiver and one 9 V alkaline battery for its handset. Batteries should last one to two seasons, depending on usage. Removing the batteries in the off-season will extend the battery life. Should the batteries loose power, the control may be operated by manually turning the control knob at the valve or by turning off the valve at the switch.

**To replace the batteries in the remote control receiver:**

1. The receiver is located to the left of the valve and it is retained to the firebox by a *Velcro* tab. Grab the receiver and pull it out from its location.
2. Slide and remove the receiver cover.
3. Replace the 4 AA alkaline batteries.
4. Replace the cover.
5. Put the receiver back in its position pushing it in so it attaches to the *Velcro* tab.

**Lighting, Operation and Rating Information****WARNING**

**DO NOT ATTEMPT TO TOUCH THE DATA PLATE WHILE THE FIREPLACE IS STILL HOT!** Let the fireplace cool first before touching it.

The Lighting, Operation and Rating information is located on a plate at the left of the valve under the burner.

To access the plate, remove the cast fret or the bottom cover, grab the plate and take it out to read it. There is important information on both sides of the plate.

**Servicing**

If any attention is required for your appliance, contact your supplier quoting the model number. It will be helpful if the appliance's serial number can also be quoted. This number is on the rating plate, which is located under the burner. The replacement parts are shown at the end of this manual. Please always quote the part number and description when requesting spare parts.

**Fireplace Control Devices**

There are three ways to control your fireplace.

1. Thermostatic Remote Control;
2. Wall Switch (optional);
3. Manual On/Off Switch.

The manual On/Off switch must be ON for the fireplace to function. It can be used to shut off the fireplace in case of emergency—see next section.

The Thermostatic Remote Control can be programmed to function automatically—see pages 24–28.

The Wall Switch (optional) can be used to turn on, off and to increase or decrease the flame height—see 1265WSK—Wall Switch Kit.

**NOTE:** The remote control in the AUTO mode will override the wall switch.

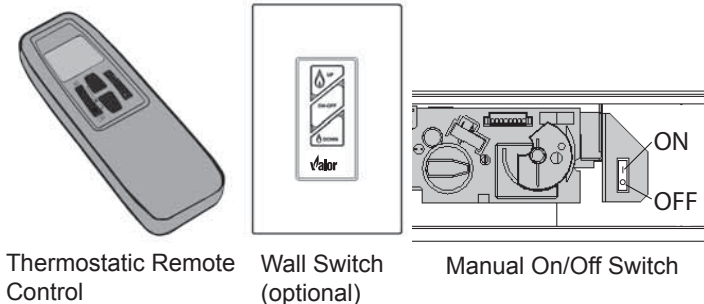

Thermostatic Remote Control

Wall Switch (optional)

Manual On/Off Switch

**How to Turn Your Fireplace OFF (including pilot)**

Familiarize yourself with each of these methods before operating your fireplace.

**Handset and Wall Switch:** Press and hold the OFF button for a second.

If the flames are on, they go down and you hear the valve motor wind down. You hear a clunk and a beep indicating that the valve has received the signal from the remote control.

**Manual ON/OFF Switch:** Press the **O** button.

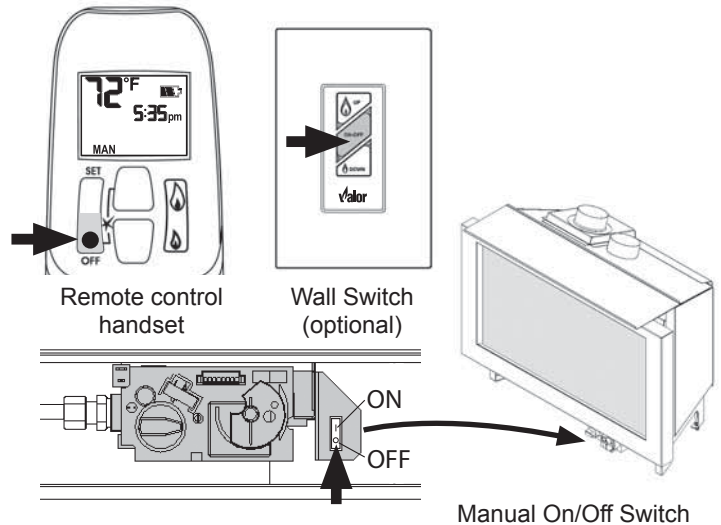

**How to Ensure Your Fireplace Cannot Be Turned ON Inadvertently**

You can use one of the two following methods to ensure that your fireplace will not turn on when you don't want it on.

**First, ensure your fireplace is turned off—including the pilot—and cold BEFORE going ahead.**

Remove all batteries from the receiver as well as the battery from the handset.

Alternately, you can prevent your fireplace from lighting by pressing the **O** button on the manual ON/OFF switch on the gas valve—see image above.

**Automatic Shut-Off (in certain conditions)**

Your fireplace's remote control is equipped with an automatic shut-off mechanism which is activated in certain conditions. See page 28 in the *Remote Control Operation* section for a description of this feature.

**NOTE:** Before using the remote control system for the first time, the receiver and the handset must be synchronized. See the section *Remote Control Initial Set-up* on page 18 of this manual.

**IMPORTANT:** BEFORE YOU BEGIN, please note that on this system, the settings of time, temperature and automatic ON/OFF can only be programmed when the function display is flashing. Be patient when programming as it can take a few seconds to set.

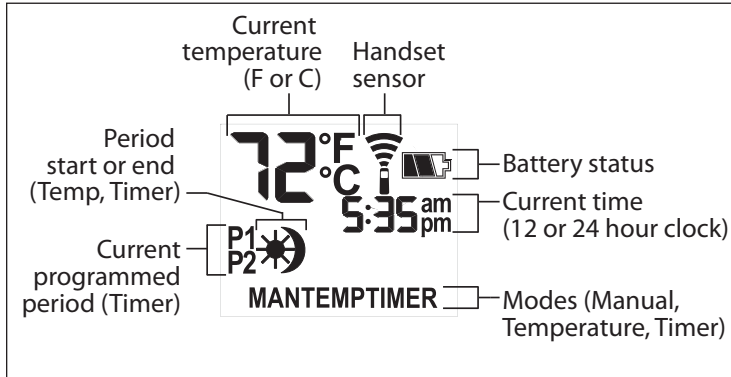

Display Overview

Note: In the TEMP or TIMER modes, the remote handset senses the room temperature and adjusts the flame accordingly.

To communicate, the handset should be within 15 feet (4.5 meters) of the fireplace.

**Do not leave the handset on the mantel or hearth.**

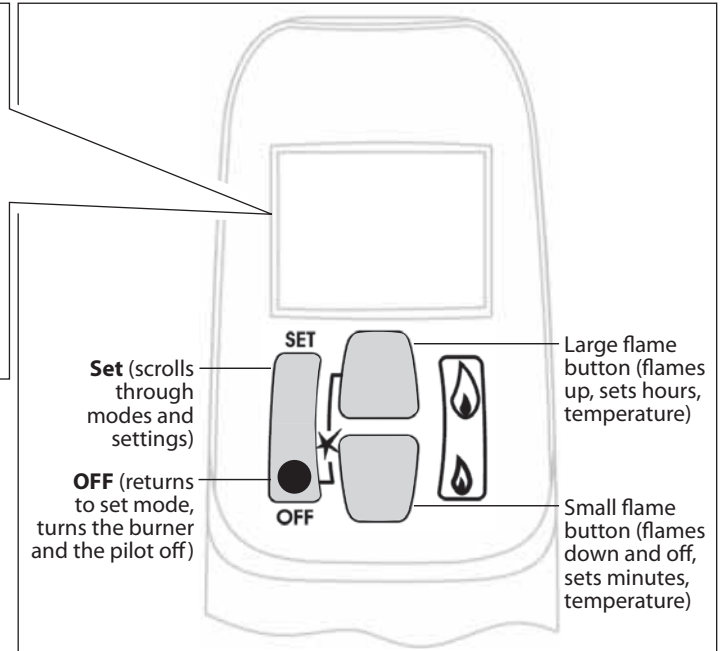

Handset Overview

## TO TURN ON APPLIANCE

### CAUTION

When pilot ignition is confirmed, motor turns automatically to maximum flame height.

- On the valve, turn MAN knob on the ON, full counterclockwise ↺ position.
- Place ON/OFF switch (if equipped) in I (ON position).



- Simultaneously press the OFF and 🔥 (large flame) buttons until a short beep confirms the start sequence has begun; release buttons.
- Continuing beeps confirm the ignition is in process.
- Once pilot ignition is confirmed, there is main gas flow.
- After main burner ignition the handset will automatically go into temperature (TEMP) control mode.

## TO TURN OFF APPLIANCE

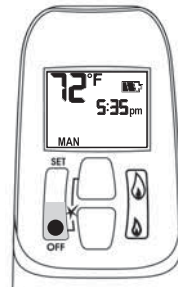

- Press OFF button.

When the pilot is off, it will take 2 minutes before it can be lit again.

### STANDBY MODE (Pilot Flame)

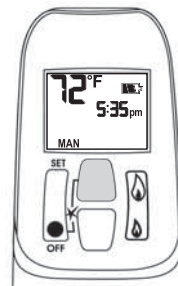

- Press and hold 🔥 (small flame) to set appliance at pilot flame.

## FLAME HEIGHT ADJUSTMENT



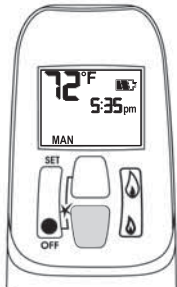

- In standby mode: Press and hold 🔥 (large flame) button to increase flame height.



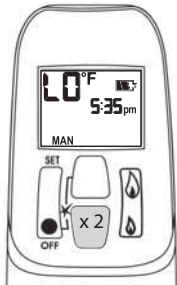

- Press and hold  (small flame) button to decrease flame height or to set the appliance at pilot flame.
- For fine adjustment tap the  (large flame) or  (small flame) buttons.

### Express Low and High Fire

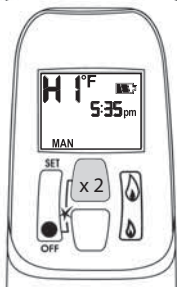

- Double-click  (small flame) button. "LO" will be displayed.  
NOTE: Flame goes to high fire first before going to designated low fire.



- Double-click  (large flame) button. Flame automatically goes to high fire. "HI" will be displayed.





### SETTING °C/24-HOUR OR °F/12-HOUR CLOCK

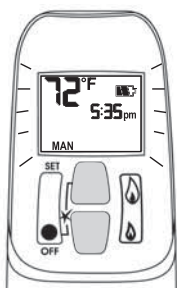

- In MAN mode, press OFF and  (small flame) buttons until display changes from Fahrenheit/12-hour clock to Celsius/24-hour clock and vice versa.

### SETTING THE TIME



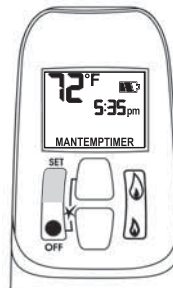

- The time display will flash after either:
  - » Installing the battery or
  - » Simultaneously pressing the  (large flame) and  (small flame) buttons.
- Press  (large flame) button to set the hour.
- Press  (small flame) button to set the minute.
- Press OFF or simply wait to return to MAN mode.

### MODES OF OPERATION

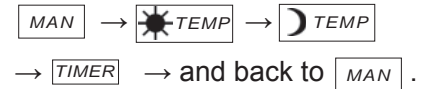

- Briefly pressing the SET button changes the mode of operation in the following order:



**NOTE:** Manual mode can also be reached by pressing either the  (large flame) or the  (small flame) buttons.

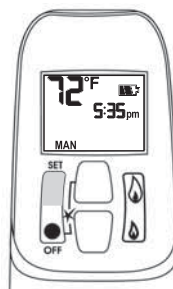

-  - **Manual Mode** - Manual Flame Height Adjustment.

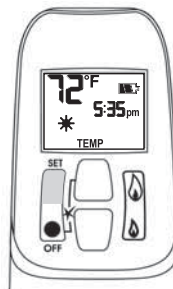

-  - **Daytime Temperature Mode** (Appliance must be in standby mode; pilot ignited) - The room temperature is measured and compared to the set temperature. The flame height is then automatically adjusted to achieve the Daytime Set Temperature.

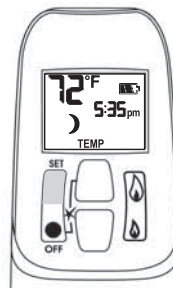

-  - **Nighttime Setback Temperature Mode** (Appliance must be in standby mode; pilot ignited) - The room temperature is measured and compared to the Nighttime Setback temperature. The flame height is then automatically adjusted to achieve the Nighttime Setback Temperature.

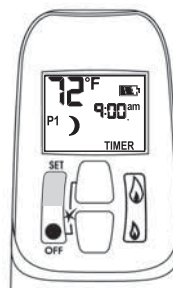

-  - **Timer Mode** (Appliance must be in standby mode; pilot ignited) - The timers P1 and P2 (Program 1, Program 2) each can be programmed to go ON and OFF at specific times. For instructions see Timer Programming Mode.

**NOTE:** The display shows the set temperature every 30 seconds.

SETTING THE ON / OFF TEMPERATURES

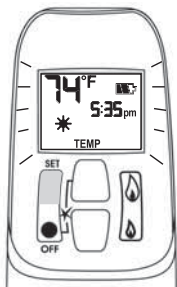

SETTING THE "DAYTIME" TEMPERATURE

Default Settings:  TEMP (sun), 23°C / 74°F



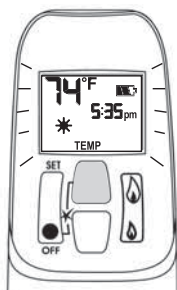

- Briefly press SET button to scroll to TEMP  (sun) mode. Hold the SET button until the TEMP flashes.

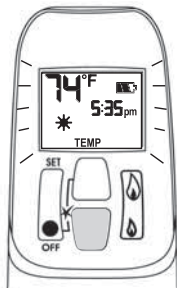

- Press  (large flame) button to increase the  Daytime Set Temperature.



- Press  (small flame) button to decrease  Daytime Set Temperature.

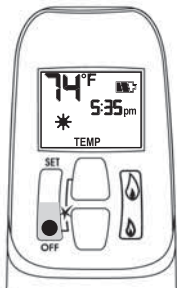

- Press OFF or simply wait to complete programming.

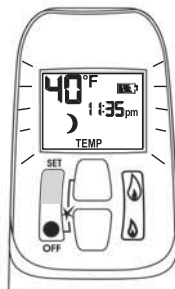

SETTING THE "NIGHTTIME SETBACK" TEMPERATURE

Default Settings:  TEMP (moon), "--" (OFF)



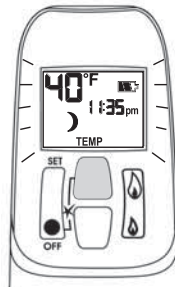

- Briefly press SET button to scroll to TEMP  (moon) mode. Hold the SET button until the TEMP flashes.

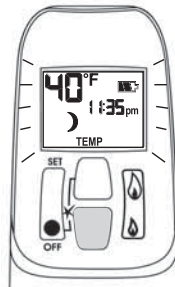

- Press  (large flame) button to increase  Nighttime Setback Temperature.



- Press  (small flame) button to decrease  Nighttime Setback Temperature.

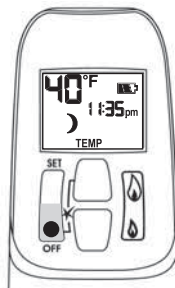

- Press OFF or simply wait to complete programming.

Tip

Set the different parameters when they are flashing.

### SETTING PROGRAM TIMERS

- You can program two periods of time between 12:00 am and 11:50 pm in each 24-hour cycle.
- The Programs P1 and P2 must be set in the following order during a 24-hour cycle: **P1** ☀, **P1** 🌙, **P2** ☀ and **P2** 🌙
- The icon ☀ indicates the beginning of the period (ON) and the icon 🌙 indicates the end of the period (OFF).
- If **P1** ☀ = **P1** 🌙 or **P2** ☀ = **P2** 🌙, the programming is cancelled.
- To keep the fireplace ON all night, set **P2** 🌙 at 11:50 am and **P1** ☀ at 12:00 am.

#### Default settings:

Program 1: **P1** ☀ 6:00 am **P1** 🌙 8:00 am  
 Program 2: **P2** ☀ 11:50 pm **P2** 🌙 11:50 pm

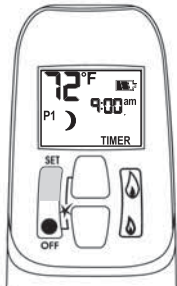

- Briefly press SET button to scroll to TIMER mode.

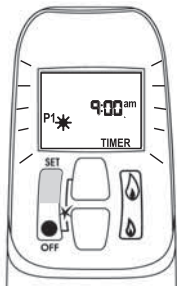

### SETTING P1 ON TIME

- Hold the SET button until **P1** ☀ (sun) is displayed and the time flashes.

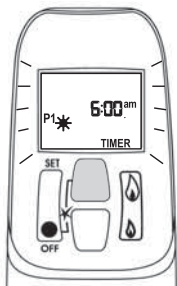

- Press 🔥 (large flame) button to set the hour.

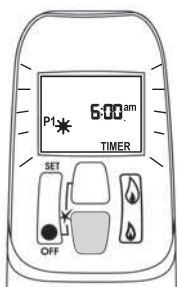

- Press 🔥 (small flame) button to set the minutes.

### SETTING P1 OFF TIME

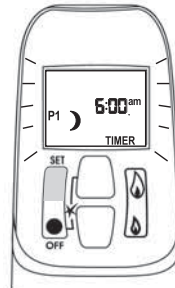

- Briefly press SET button to scroll to TIMER **P1** 🌙 (moon) while the time flashes.

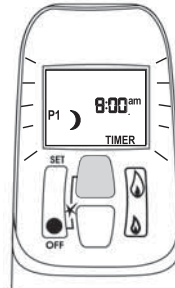

- Press 🔥 (large flame) button to set the hour.

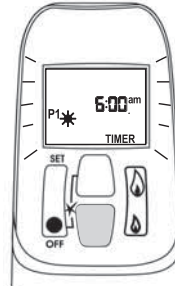

- Press 🔥 (small flame) button to set the minutes.

### SETTING P2 ON TIME

- Briefly press SET to scroll to TIMER mode **P2** ☀ (sun) while the time flashes.
- Follow the instructions given to set P1 ON time.

### SETTING P2 OFF TIME

- Briefly press SET to scroll to TIMER mode **P2** 🌙 (moon) while the time flashes.
- Follow the instructions given to set P1 OFF time.

Press OFF button to save these settings. The timers are programmed. See the diagram on programming sequences on the following page.

#### Tip

If you want to program only one period, program **P1** ☀ and **P1** 🌙 with desired times and program **P2** ☀ and **P2** 🌙 with the same time as **P1** 🌙.

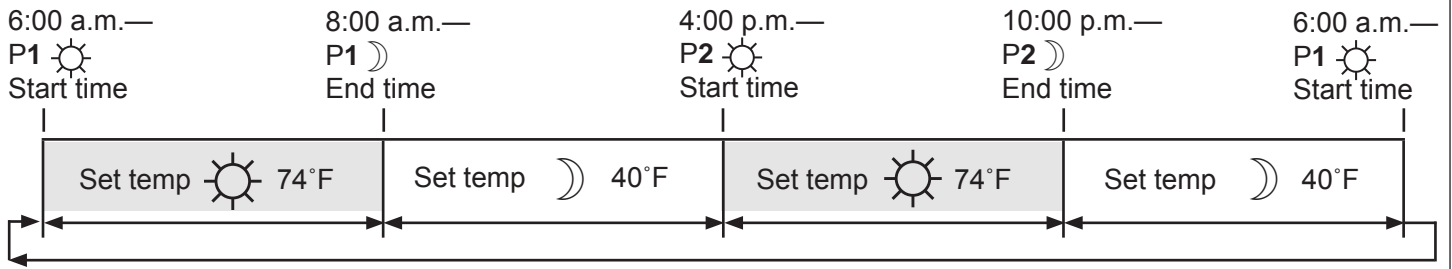
**Timer Programming Example** (default temperatures shown)**AUTOMATIC TURN DOWN**

- **No communication.** If there is no communication between the receiver and the handset for a period of 6 hours, the appliance goes into pilot mode.
  - **No change in flame height.** If there is no change in flame height for a period of 6 hours, the appliance goes into pilot mode.
- NOTE:** In **TEMP** or **TIMER** modes, the flame height will vary according to room temperature. The appliance will continue to work normally. However, if the room temperature remains the same for 6 hours, the appliance will go into pilot mode.

**AUTOMATIC SHUT OFF**

- **Low batteries in the receiver.** With low battery power in the receiver the system shuts off completely.
- NOTE:** This does not apply when the power supply is interrupted.
- **No change in pilot.** The appliance shuts off completely when it is continually in pilot position—without any change—for a period of 5 days.

**LOW BATTERY INDICATION****CAUTION**

**DO NOT USE** a screwdriver or other metallic object to remove the batteries from the battery box or the handset! This could cause a short circuit.

**Remote handset:** The battery icon  will show when the battery needs to be replaced. Replace with one 9 V **alkaline** battery.

**Receiver:** Three short 'beeps' will sound when the motor turns when the batteries need to be replaced. Replace with four 1.5 V **alkaline** batteries.

**HANDBSET / RECEIVER MATCH**

The remote control handset and receiver are programmed to function together. In case of a replacement of the handset or the receiver, you will need to reset the receiver to allow them to function together. Contact your dealer for details.

**Options****Decorative Cast Iron Frets (optional)**

- RA24CV**—Contemporary, Vintage Iron Finish  
**RA24AV**—Avant-Garde. Vintage Iron Finish  
**RA24TB**—Traditional, Black Finish  
**1225VFB**—Ventana Fret, Black

**Venting**

Pipe—generic 3" diameter flexible aluminum liner approved for gas venting—see list above.

Termination—Miles Industries' **559CLT** Co-Linear Termination and **559SFK** Square Flashing Kit are recommended for terminating existing masonry chimney applications—see list above for other approved venting accessories.

**Other Accessories**

- 555CFK**—Circulating Fan Kit with 6'-0" c/w grounded cord set.  
**1265WSK**—Wall Switch Kit

**Conversion Kits**

- RA24NK**—to convert from LPG to **Natural Gas**  
**RA24PK**—to convert from Natural Gas to **LPG**

**Hearth Gate (optional)**

Hearth gates such as Cardinal's VersaGates are available at retail stores carrying safety products for children.

**FOR YOUR SAFETY, READ BEFORE LIGHTING**

**WARNING:** If you do not follow these instructions exactly, a fire or explosion may result causing property damage, personal injury or loss of life.

- A. This appliance has a pilot which must be lighted by hand or by remote control. Follow these instructions exactly. To save gas, turn the pilot off when not using the appliance for a prolonged period of time.
- B. **BEFORE LIGHTING**, smell all around the appliance area for gas. Be sure to smell next to the floor because some gas are heavier than air and will settle on the floor.
- WHAT TO DO IF YOU SMELL GAS
- Do not try to light any appliance.
  - Do not touch any electric switch; do not use any phone in your building.
  - Immediately call your gas supplier from a neighbor's phone. Follow the gas supplier's instructions.
  - If you cannot reach your gas supplier, call the fire department.
- C. Use only your hand to push in or turn the control knobs. Never use tools. If the knobs will not push in or turn by hand, don't try to repair them; call a qualified service technician. Force or attempted repair may result in a fire or explosion.
- D. Do not use this appliance if any part has been under water. Immediately call a qualified service technician to inspect the appliance and to replace any part of the control system and any gas control, which has been under water.

**LIGHTING INSTRUCTIONS**

1. STOP! Read the safety information above. Dependent on model, switch #1 may be mounted directly to valve see Fig 2A.

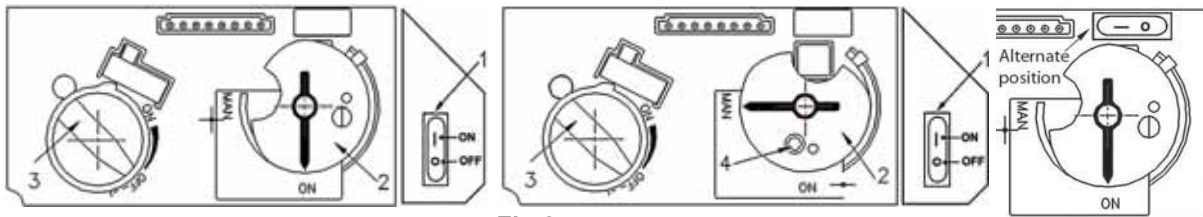

Fig 1



Fig 2

Fig 2A

2. SET ON/OFF SWITCH (1) TO "OFF" POSITION.

- Wait five (5) minutes to clear out any gas, then smell for gas, including near the floor. If you smell gas, STOP! Follow "B" in the safety information above on this label. If you don't smell gas, go to the next step.

3. AUTOMATIC IGNITION (fig. 1): Locate the pilot (fig. 3.) inside of firebox at Left Hand side.

- ON/OFF switch (1) in ON position, MAN-knob (2) in ON position; set Flame Adjustment knob (3) to lowest setting (U);
- On the remote control handset, press and hold the 'off' button and  (large flame) simultaneously; a short acoustic signal confirms the start has begun;
- Further short acoustic signals indicate the ignition process is in progress;
- When the pilot is lit, the Flame Adjustment knob (3) will automatically rotate to the highest setting.
- Press the  (small flame) on the remote control handset to reduce the flame height.

4. MANUAL IGNITION (fig. 2): With the window off, locate the pilot (fig. 3) inside of firebox at Left Hand side;

- ON/OFF switch (1) in ON position, MAN-knob (2) in MAN position;
- Set Flame Adjustment knob (3) to the lowest setting (U);
- Push down the metallic core (4) with a pen or similar instrument; this will establish the pilot gas flow;
- Light gas at the pilot (5) with a match;
- Continue holding down metal core (4) for about 10 seconds; after release, pilot should remain lit;
- If the pilot will not stay lit after several tries, turn the gas control knob (3) to "OFF" (U) and call your local service technician or gas supplier.

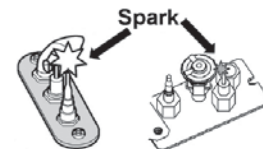



Fig 3

Reinstall the window and set the MAN-knob (2) to "ON"; turn Flame Adjustment knob (3) up (U) or down manually or use the up/down 'flame' buttons on the remote control handset to adjust the flame height.

**TO TURN OFF GAS TO APPLIANCE**

1. AUTOMATIC SHUT-OFF (using the remote control handset):

- Press and hold the  (small flame) on the remote control handset to shut-off the main burner gas flow;
- Press "OFF" button on remote handset to shut-off the appliance, including pilot flame.

2. MANUAL SHUT-OFF (using only the ON/OFF switch (1))

- Press "O" the ON/OFF switch (1) to shut-off the appliance.

# Wiring Diagram

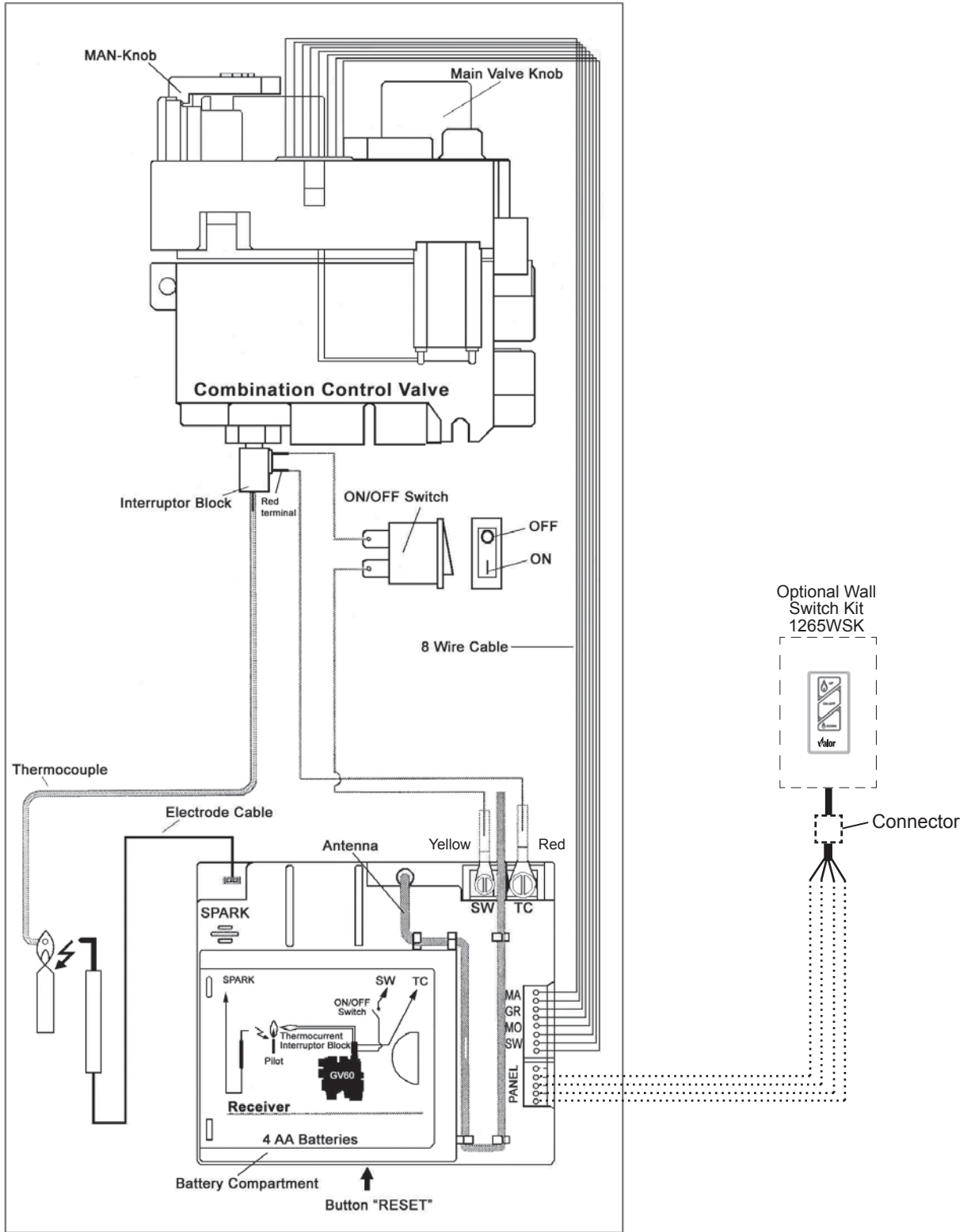

GV60 Wiring Diagram

<b>Approved Direct Vent Suppliers for Valor Models 739, 780, 785 and RF24DV</b>									
		<b>Venting Parts Code / availability by Manufacturer</b>							
		SIMPSON DURA-VENT	SELKIRK	ICC EXCEL DIRECT	SECURE VENT	RLH INDUSTRIES	AMERIVENT	MILES INDUSTRIES	
<b>Venting Parts Description</b>									
<b>Termination Caps</b>	<b>Vertical</b>	Standard Co-axial	46DVA-VC	4DT-VC	TM-4VT	—	HSDV4658-1313	4DVC 4DH-1313	—
		High Wind Co-axial	46DVA-VCH	—	—	SV4CGV	—	—	—
		Extended Co-axial	46DVA-VCE	—	—	—	—	—	—
		Co-linear	—	—	—	3PDVCV	HS-C33U-99 HS-C33F-1313	HCL-99-33 HCL-913-33 HCL-1313-33	559CLT
<b>Vent Adapters / Couplers</b>	Universal Adapter 3” Flex Coupler	2150	—	TM-CFAA3	—	—	—	—	
	Co-linear Flex Connector	46DVA-ADF	—	—	—	—	—	—	
	Co-axial-to-Co-linear Adapter	46DVA-GCL	—	TM-4CAA	—	—	4DCAB33	556CLA	
	Co-linear-to-Co-axial Adapter	46DVA-GK	—	TM-4CTA	—	—	4DCAT33	—	
<b>Aluminum Flexible Liner</b>	3” diameter	NOTE: 2-ply liner approved to CAN/ULC S635 suitable for venting gas appliances. As manufactured by Z-Flex.							
		2280 Series	3” ACFL	—	—	—	3AFL-35	—	
<b>Flashings</b>	Roof Flashing 0/12-6/12	46DVA-F6	4DT-AF6	TF-4FA	SV4FA	—	4DF (0/12-5/12)	—	
	Roof Flashing 7/12-12/12	46DVA-F12	4DT-AF12	TF-4FB	SV4B	—	4DF12 (6/12-12/12)	—	
	Flat Roof Flashing	46DVA-FF	—	TF-4F	SV4F	—	—	559FSK	
	Masonry Flashing	—	—	TF-4MF	—	—	—	—	

- Notes:**
- 1) Follow instructions supplied with each manufacturer's components.
  - 2) Termination caps manufactured by RLH Industries or American Metal Products are from Homestyle Chimney Collection and can be ordered in one of the following finishes: a) aluminum; b) black powder coated; c) solid copper.

If you have a problem with this unit, please contact your dealer or supplier immediately. Under no circumstances should you attempt to service the unit in any way by yourself. The warranties in paragraphs 1 and 2 are provided only to the first purchaser/user of this unit, are not transferable and are subject to the conditions and limitations in paragraphs 3, 4 and 5. Please review the conditions and limitations carefully and strictly follow their requirements.



### 1. Extended Warranty Coverage

For a period of up to ten (10) years, Miles Industries Ltd., (the "Company") or its appointed distributor will at its option pay the initial purchaser for the repair of, or will exchange the following parts or components which are found to be defective in material or workmanship under normal conditions of use and service:

Part or Component	Defect Covered	Maximum Warranty Period
Exterior steel casing	Corrosion	10 years
Glass	Loss of structural integrity	10 years
Cast iron parts	Corrosion	10 years
Firebox and heat exchanger	Corrosion (but not discoloration) causing loss of structural integrity	10 years

### 2. Two-Year Parts Warranty

In addition, for two (2) years from the date of purchase, the Company, at its option, can repair or exchange all parts and components not listed above but that are found to have a *bona fide* defect in material or workmanship under normal conditions of use.

### 3. Conditions and Limitations

- a) The warranty registration card must be completed by the initial owner and returned to the Company within 90 days of purchase.
- b) Installation and maintenance must be performed by an authorized and trained dealer in accordance with the Company's installation instructions.
- c) This warranty is void where installation of the unit does not conform to all applicable codes including national and local gas appliance installation codes and building and fire codes.
- d) The owner must comply with all operating instructions.
- e) The Company is not responsible for the labor costs to remove defective parts or re-install repaired or replacement parts.
- f) The first purchaser or user of the unit will be responsible for any shipping charges for replacement parts as well as travel time incurred by the dealer to perform the warranty work.
- g) This warranty applies to non-commercial use and service and is void if it is apparent that there is abuse, misuse, alteration, improper installation, accident or lack of maintenance to the unit.
- h) This warranty does not cover damage to the unit through:
  - i) Improper installation, operational or environmental conditions.
  - ii) Inadequate ventilation in the area or competition for air from other household equipment or appliances.
  - iii) Damage due to chemicals, dampness, condensation, or sulphur in the fuel supply lines which exceeds industry standards.
- i) This warranty does not cover glass, log breakage or damage to the unit while in transit.
- j) The Company does not allow anyone to extend, alter or modify this warranty and assumes no responsibility for direct, indirect or consequential damages caused by the unit. State or provincial laws where the first purchaser or user resides may provide specific rights to extend this warranty and, if so, the Company's sole obligation under this warranty is to provide labor and/or materials in accordance with those laws.

### 4. Discharge of Liability

After two (2) years from the date of purchase, the Company may, at its option, fully discharge all obligations under this warranty by paying to the first purchaser/user the wholesale price of any defective parts.

### 5. No Other Warranty

All obligations to repair this unit are defined in this warranty. Some states or provinces may specifically mandate additional warranties on the part of manufacturers, but in the absence of such specific legislation, there is no other warranty or obligation expressed or implied.

KEY	DESCRIPTION	PART NUMBER
1	Firebox Assembly	400634AH
2	Restrictor (2)	400767
3	Convection Baffle	4000744
4	Fret Support LH	4002837BY
5	Wing Nut (2)	4000741
6	Leg LH	4000662
7	Leveling Bolt (2)	4000242
8a	Log Support NG	4000621
8b	Log Support LPG	4001456
9	Leg RH	4000663
10	Fret Support RH	4002836BY
11	Thumbscrew # 10-32x1/2" (4)	4000753
12a	Burner Tray Assy DV, NG	4000635
12b	Burner Tray Assy DV, LPG	4000653
13	Airshutter	4000657
14a	Injector Elbow NG 82-580	720A580
14b	Injector Elbow LP 92-260	9730007
15	Valve Tray, DV	4000714
16	Gasket Rear	4000642
17	Gasket LH Side	4000643
18	Gasket Front	4000641
19	Gasket RH Side	4000644
20	Burner Support	4000579
21	Burner	4000599
22	Shutter Slider	4000759
23	Front Log Bracket	4000739
24	Olive 8mm	519779
25	Olive Nut	523389
26	Pipe Valve to main Burner (incl. olive & nuts)	4000600
27	Tube Nut	523389
28	Valve Mount	4000141
29a	190 Series Pilot Assy NG	4000727
29b	190 Series Pilot Assy LPG	4000728
30	Electrode Nut	720A200
31	Pilot Gasket	4000715
32	Pilot Bracket 190 Series	4000729
	Threaded Plug Pilot Bracket	4000726
33	Thermocouple	4000061
34a	NG Pilot Injector #51	4000735
34b	LPG Pilot Injector #30	4000736

KEY	DESCRIPTION	PART NUMBER
35	2-Flame Pilot Hood	4000730
36	Electrode	720A543
37	Pilot Tube	4000732
38	Thermocurrent Interruptor	4001037
39	GV60 Valve	4000873
40	Servo Motor	4001190
41	Switch with Cable	4001036
42	Cable Interrupter/Receiver	4001035
43	Ignition Cable	4001039
43a	Ignition Cable Insulation Sleeve	4002244
44	Receiver	4001911
45	Handset	4001910
46	Wiring Harness	4001187
47	Handset Wall Holder	9000008
48	Window Assy	4002860
49	Bottom Cover	4002835BY
50a	Log Set, Retrofire NG	4000603
50b	Log Set Retrofire LPG	4000603P
51a	Rear Log NG	4000688
51b	Rear Log LPG	4000688P
52	RH Log	4000691
53	Centre Log	4000692
54	Front Log	4000689
55	LH Log	4000690
56	Switch Bracket	4001070

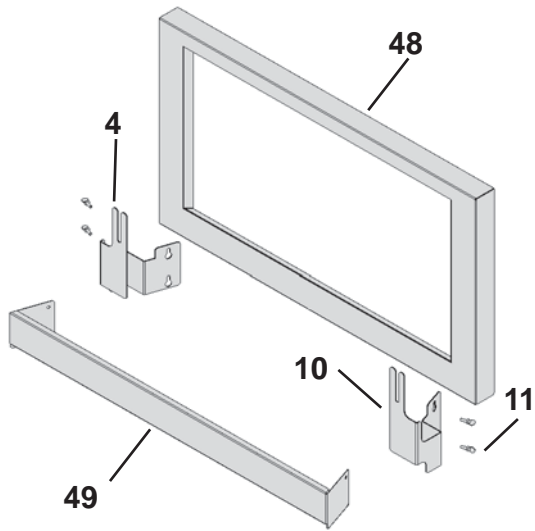
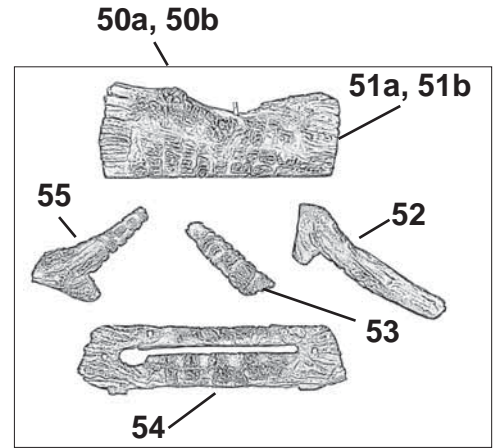
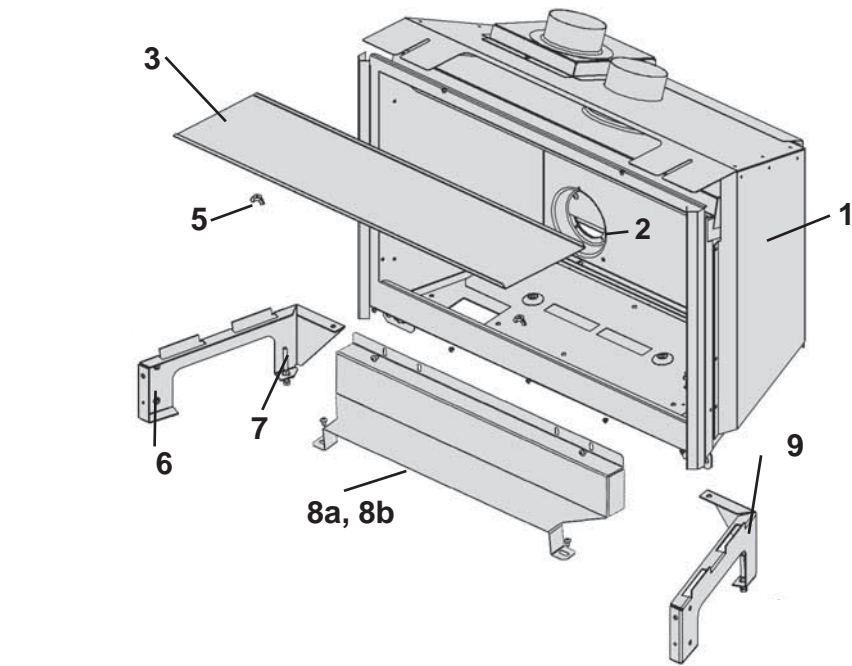

12a, 12b

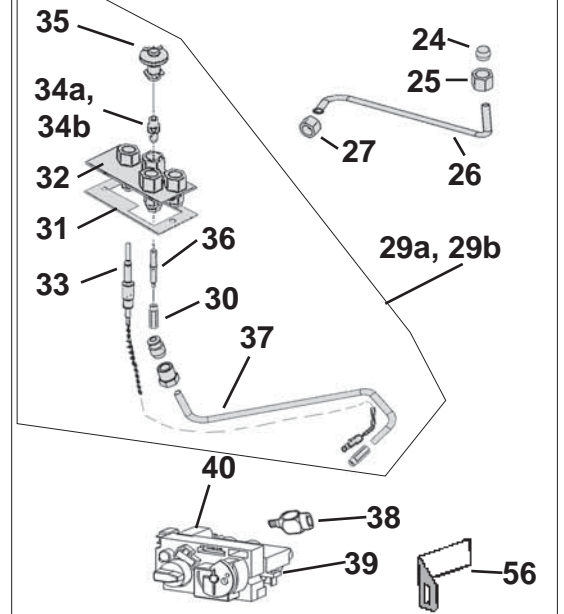
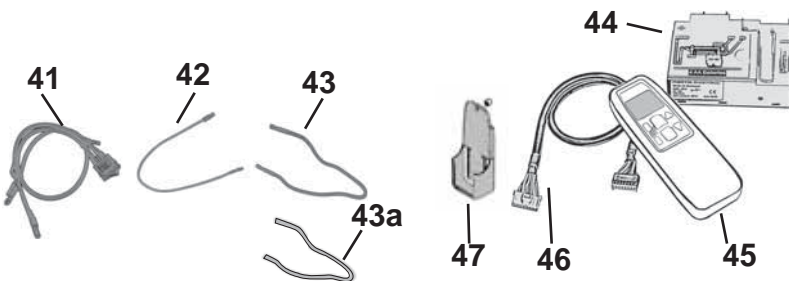
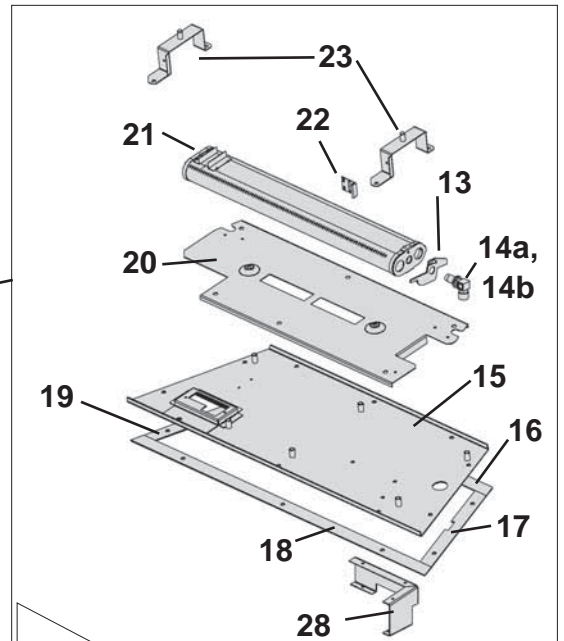

## Thank You ...

For purchasing a Valor by Miles Industries. Your new radiant gas heater is a technical appliance that must be installed by a qualified dealer.

*Please circle where appropriate - ask your installer if in doubt: Information provided will be used for customer records only.*



Model: <b>RF24ID</b> <b>NG</b> (natural gas) <b>LPG</b> (propane)				<b>Serial No:</b>			
Fret code/description (e.g. RA24TB Traditional Black Fret):							
Purchase date (mm-dd-yyyy):							
Home Owner Name:							
Address:							
City:			Province/State:			Postal Code/Zip:	
Phone: (    )			Email Address:				
Store Type:		Fire shop	Hardware	Contractor	Other		
Purchase Decision:		Male	Female	Both			
Age:	Under 30	30-39	40-49	50-59	60+		
Heard of this product through:							
	Friend	Brochure	Advertising	Mailing	Store	Internet	Other
Installation Type:							
	New home	Renovation	Other				
Reason for Purchase:							
Performance	Flame Appeal	Design	Control	Previous owner	Recommendation	Price	Other
Dealer Name:							
Address:							
City:			Province/State:			Postal Code/Zip:	
Phone: (    )							

Cut out page, fill information, and mail to Miles Industries Ltd.

Online Warranty registration at [www.valorfireplaces.com](http://www.valorfireplaces.com)



Tape Shut



Fold here



Postage  
needed

Miles Industries Ltd.  
190 - 2255 Dollarton Highway  
North Vancouver, BC V7H 3B1  
Canada

Online Warranty registration at [www.valorfireplaces.com](http://www.valorfireplaces.com)



*Thank you for choosing a Valor Product*